



INTENSITY[®]
AIR CONDITIONING



ROOFTOP PACKAGE
COOLING ONLY 20 and 25 Tons.

IPCH240KF-6, IPCH300KF-6.

INSTALLATION & OWNER'S MANUAL







ACCESSORIES.....	1
GENERAL INFORMATION.....	1
UNIT DIMENSIONS.....	2
LOCATIONS AND RECOMMENDATIONS.....	4
INSTALLATION.....	4
ELECTRICAL WIRING.....	6
SPECIFICATION.....	10
START-UP.....	16
MAINTENANCE.....	16

■ **Nomenclature**

CODE	NAME
C/O	Cooling Only
E/Heater+C	Cooling units with Electric Heater
Hor.	Horizontal Units

1. ACCESSORIES

Tab.1-1

Name of accessories	Qty	Shape
Manual	1	
Drain outlet	1	
Snap ring	1	
Drain pipe	1	
Wire controller	1	

2. GENERAL INFORMATION

Warnings and Cautions appear at appropriate locations throughout this manual.

Read these carefully.



WARNING: Indicates a potentially hazardous situation which, if not avoided, could result in death or serious injury.



CAUTION: Indicates a potentially hazardous situation which, if not avoided, may result in minor or moderate injury. It may also be used to alarm against unsafe practices and where property-damage-only accidents could occur.



CAUTION

- Read this entire manual before beginning installation procedures.
- Bodily injury can result from high voltage electrical components, fast moving fans. For protection from these inherent hazards during installation and servicing, the electrical supply must be disconnected.
- If operating checks must be performed with the unit operating, it is the technicians responsibility to recognize these hazards and proceed safely.



WARNING

- **Ask your dealer for installation of the air conditioner.**
Incomplete installation performed by yourself may result in a water leakage, electric shock, and fire.
- **Ask your dealer for improvement, repair, and maintenance.**
Incomplete improvement, repair, and maintenance may result in a water leakage, electric shock, and fire.
- **In order to avoid electric shock, fire or injury, or if you detect any abnormality such as smell of fire, turn off the power supply and call your dealer for instructions.**
- **Never replace a fuse with that of wrong rated current or other wires when a fuse blows out.**
Use of wire or copper wire may cause the unit to break down or cause a fire.
- **Do not insert fingers, rods or other objects into the air inlet or outlet.**
When the fan is rotating at high speed, it will cause injury.
- **Never use a flammable spray such as hair spray, lacquer or paint near the unit.** It may cause a fire.
- **Never inspect or service the unit by yourself.**
Ask a qualified service person to perform this work.
- **Keep far away from high-frequency equipment.**
- **Keep away from the following places:**
A place where it is full of oil, gas; places where salty air surrounding(near the coast); and a place where is caustic gas(the sulfide in hot spring). Location in above places may cause malfunction or shorten the life span of the machine.
- **In the case of extremely strong wind, please prevent the air from flowing backwards into the outdoor unit.**
- **Snow canopy is necessary in snowfall places on the outdoor unit. Please consult the local dealer for details.**
- **In the frequent thunderstruck place, lightning proof actions should be taken.**
- **To prevent refrigerant leak, contact your dealer.**
When the system is installed and runs in a small room, it is required to keep the concentration of the refrigerant, if by any chance coming out, below the limit. Otherwise, oxygen in the room may be affected, resulting in a serious accident.
- **The refrigerant in the air conditioner is safe and normally does not leak.**
If the refrigerant leaks in the room, contact with a fire of a burner, a heater or a cooker may result in a harmful gas.
- **Turn off any combustible heating devices, ventilate the room, and contact the dealer where you purchased the unit.**
Do not use the air conditioner until a service person confirms that the portion where the refrigerant leaks is repaired.
- **If the supply cord is damaged, it must be replaced by the manufacturer or its service agent or a similarly qualified person in order to avoid a hazard.**
- **The temperature of refrigerant circuit will be high, please keep the interconnection cable away from the copper tube.**
- **The appliance should not be used by children without supervision.**

3. UNIT DIMENSIONS

Units: mm

■ 20 Tons C/O Units (Hor.)

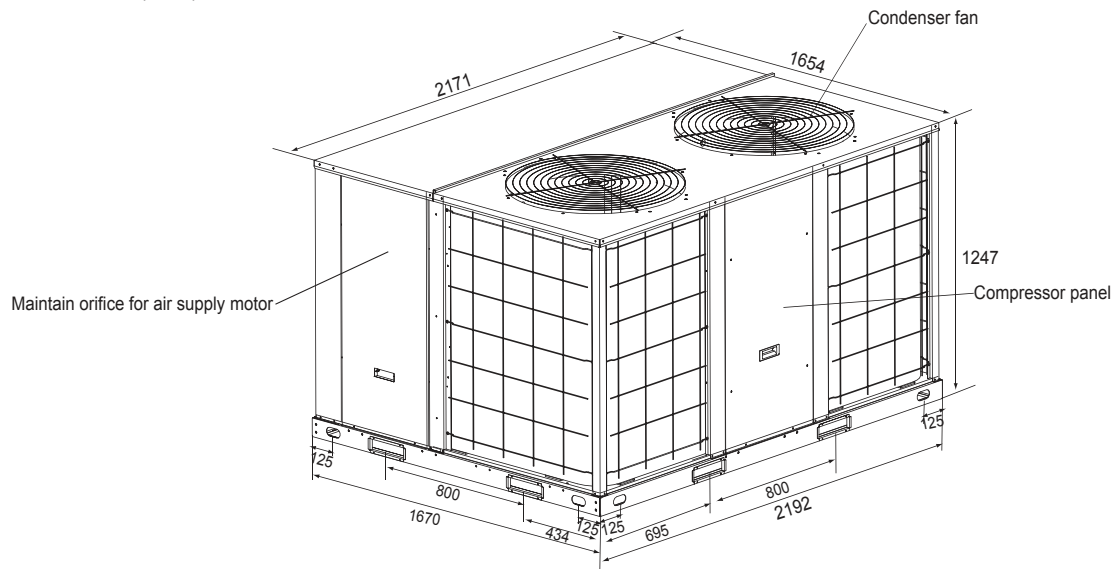

Fig. 3-1

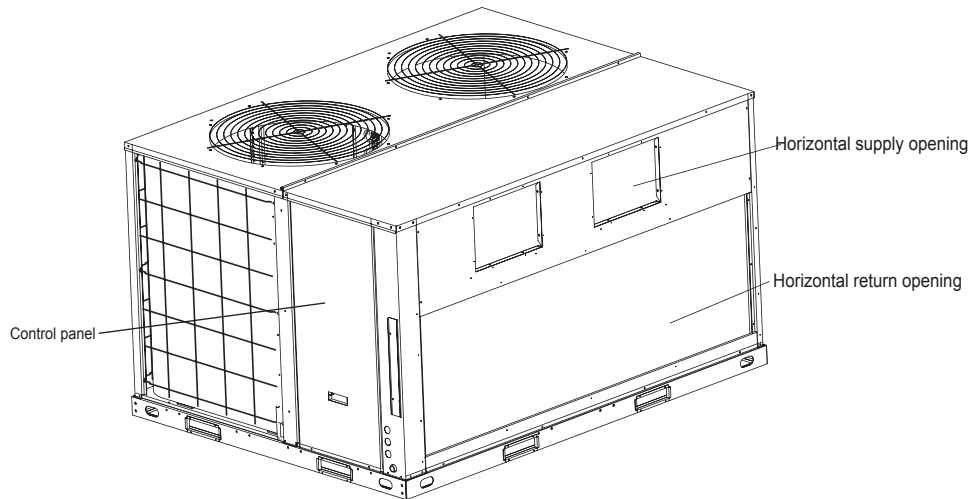

Fig. 3-2

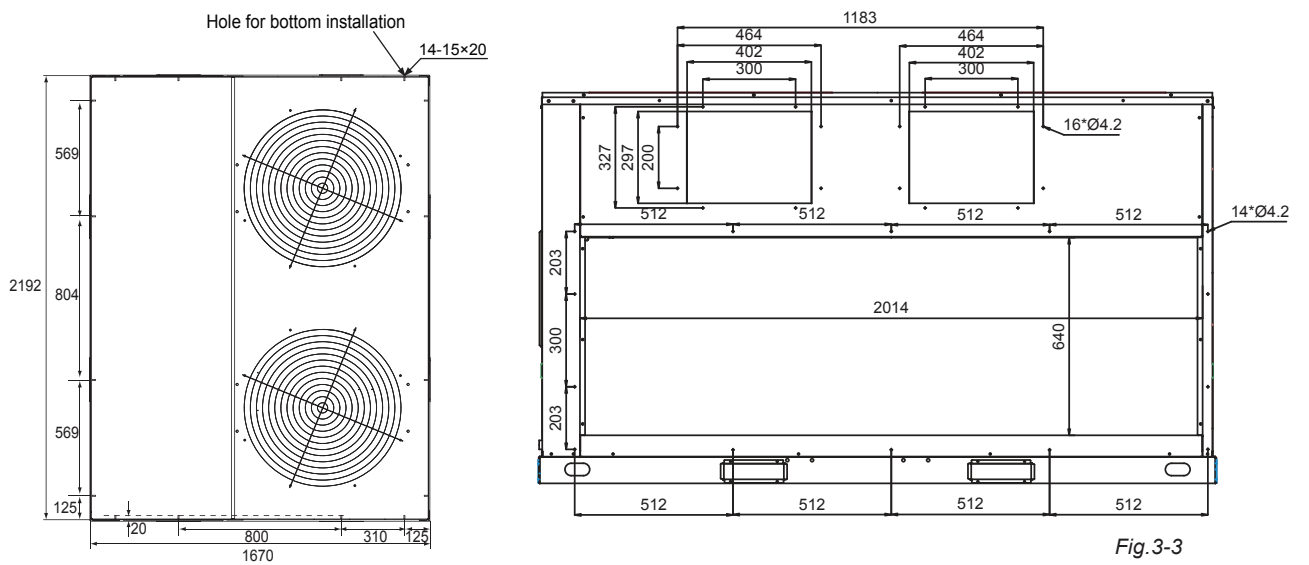

Fig. 3-3

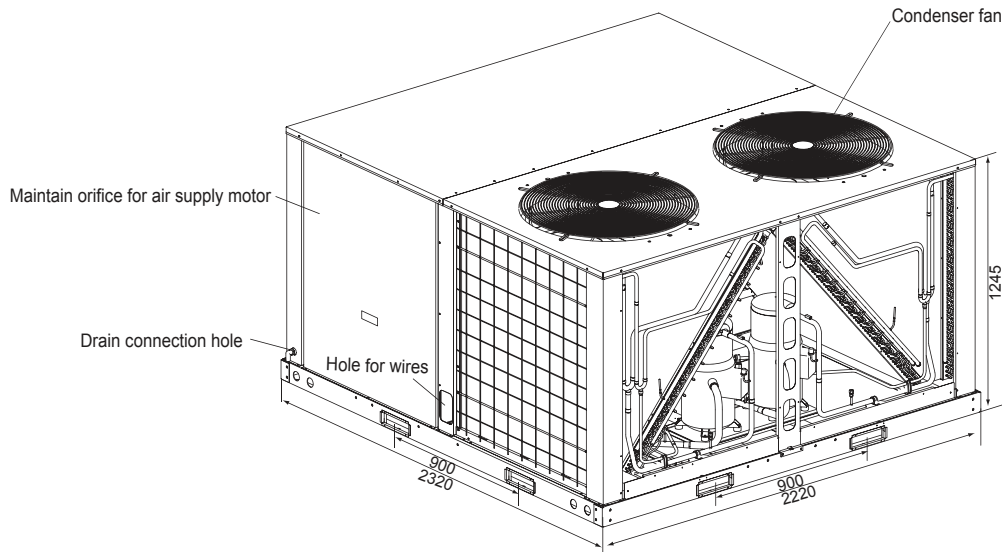

Fig.3-4

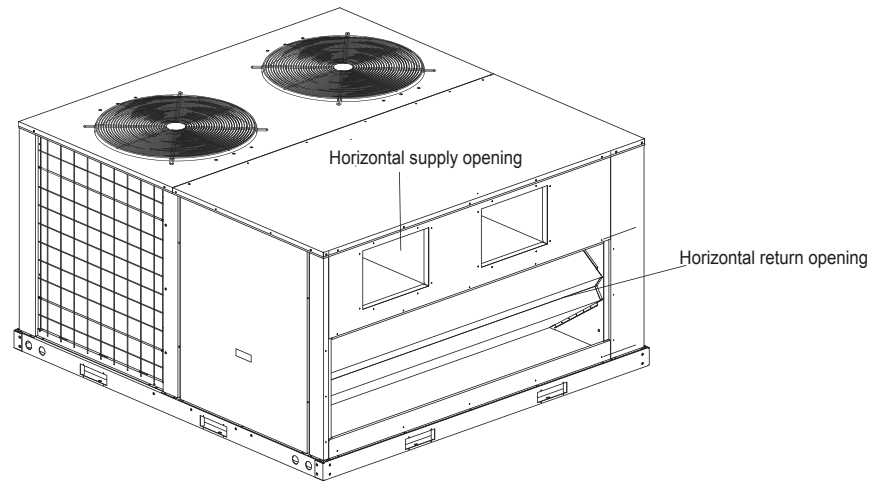

Fig.3-5

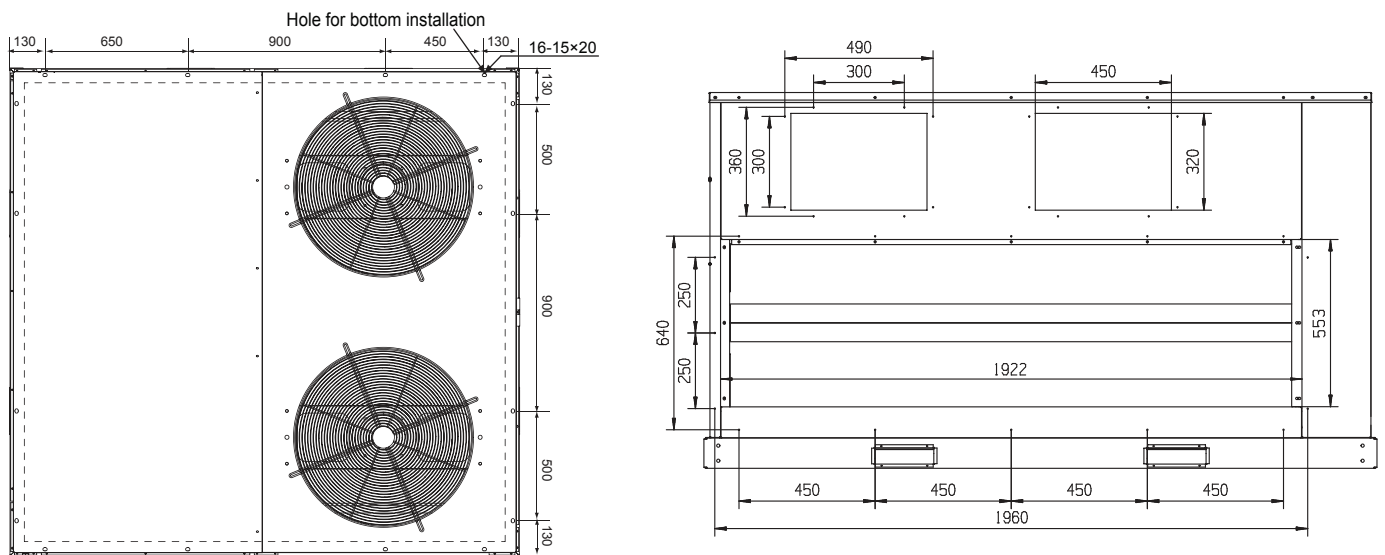

Fig.3-6

4. LOCATIONS AND RECOMMENDATIONS

4.1 Horizontal airflow application

- These units are designed and certified for outdoor installations. These units may be installed directly on wood flooring or on Class A, Class B, or Class C roof covering material.
- Location of the unit must allow service clearance around it. Clearance of the unit must be given careful consideration.
- Check the handling facilities to ensure the safety of personnel and the unit(s).
- Caution must be taken at all times to avoid Personal injuries and/or damage to equipment.
- The unit must be mounted level for proper drainage of water through the holes in the base pan.
- The unit must not be exposed to direct roof water runoff.
- Flexible duct connectors must be of a flame retardant material. All duct work outside of the structure must be insulated and weatherproofed in accordance with local codes.
- Holes through exterior walls must be sealed in accordance with local codes.
- All fabricated outdoor ducts should be as short as possible.

4.2 Clearances

- The recommended clearances for single-unit installations are illustrated in Fig.4-1. These minimum requirements are not only an important consideration when determining unit placement, but they are also essential to ensure adequate serviceability, maximum capacity, and peak operating efficiency.
- Any reduction of the unit clearances indicated in these illustrations may result in condenser coil starvation or the recirculation of warm condenser air. Actual clearances which appear to be inadequate should be reviewed with a local engineer.
- See the unit's nameplate for the absolute minimum clearance between the unit and any combustible surface(s).

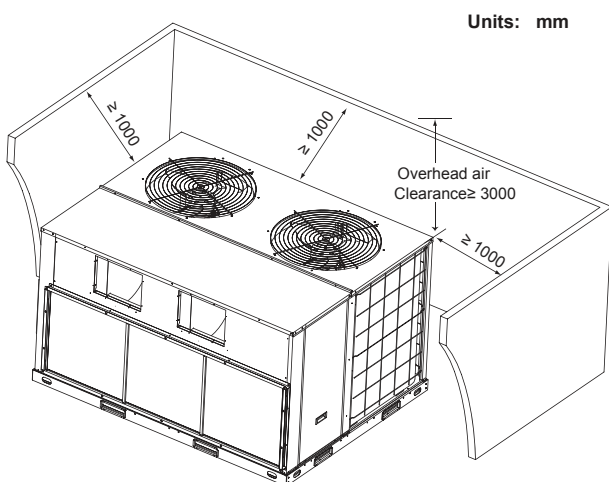

Fig.4-1

5. INSTALLATION

5.1 Lifting

- Rigging cables should have adequate capability to resist 3 times weight of unit. Before lift, please check and ensure that hooks are holding tightly to unit and lifting angles are no less than 60°. (See Fig. 5-1)
- Cloth material or hard-paper should be padded in the contact place between unit and rigging cable. Rigging cable should be entwined a round at the hook for prevent danger by cable slip because of weight unbalance.
- During lifting, anyone forbidden lingering under the lifting unit.

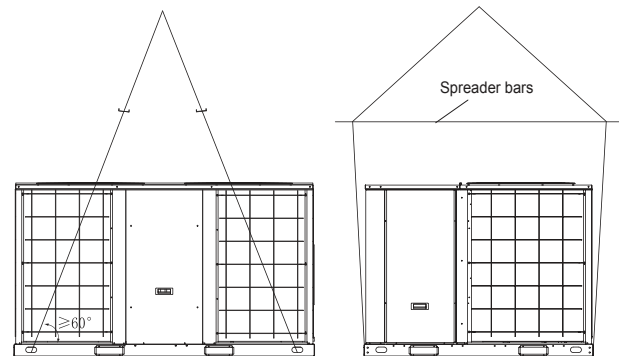

Fig.5-1

5.2 Rooftop-units

- **For roof top applications using a field fabricated frame and ducts, use the following procedure:**
- The frame must be located and secured by bolting or welding to the roof. Flashing is required.
- The hole in the roof must be prepared in advance of installing the unit.
- Secure the ducts to the roof.
- Place the unit on the frame or roof curb.
- Secure the unit to the frame or roof curb.
- Insulate any ductwork outside of the structure with at least 2 inches of insulation and then weatherproof. There must be a weatherproof seal where the duct enters the structure.
- Complete the installation according to the instructions in the following sections of this manual.
- Typical rooftop application with frame. ((See Fig. 5-2)

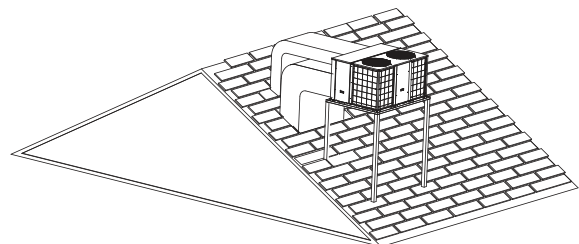

Fig.5-2

5.3 Ground level-horizontal units

- For ground level installations, the unit should be positioned on a pad in the size of the unit or larger. The unit must be level on the pad. The pad must not come in contact with the structure. Be sure the outdoor portion of the supply and return air ducts are as short as possible.
- Proceed with the installation as follows:
 - Place the unit on the pad.
 - Attach the supply and return air ducts to the unit.
 - Insulate any ductwork outside of the structure with at least 2 inches of insulation and weatherproof. There must be a weatherproof seal where the duct enters the structure.
 - Complete the installation according to the instructions in the following sections of this manual.
- Typical ground level application

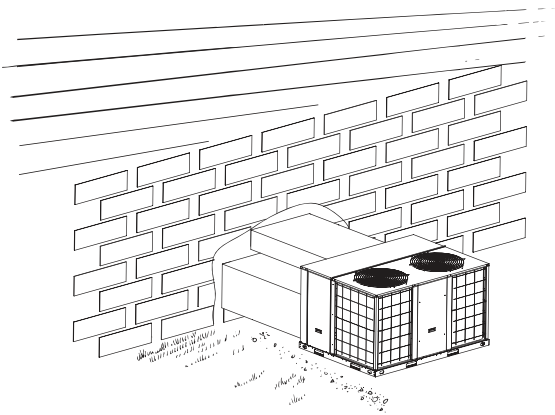

Fig.5-3

5.4 Condensate drain piping

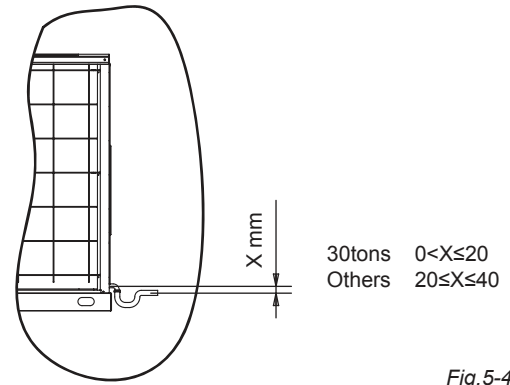
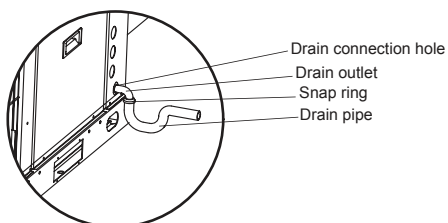
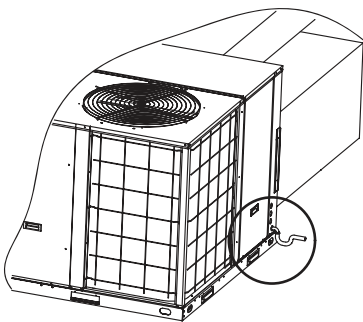

Fig.5-4

5.5 Ductwork

- Attaching horizontal ductwork to unit

All conditioned air ductwork should be insulated to minimize heating and cooling duct losses. Use a minimum of 2 inches of insulation with a vapor barrier. The outside ductwork must be weatherproofed between the unit and the building.

When attaching ductwork to a horizontal unit, provide a flexible watertight connection to prevent noise transmission from the unit to the ducts. The flexible connection must be indoors and made out of heavy canvas.

NOTE
Do not draw the canvas taut between the solid ducts.

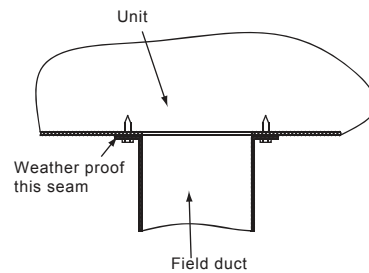

Fig.5-5

6. ELECTRICAL WIRING



WARNING

- An all-pole disconnection switch having a contact separation of at least 3mm in all poles should be connected in fixed wiring.
- The appliance shall be installed in accordance with national wiring regulations.
- An all-pole disconnection device which has at least 3mm separation distance in all pole and residual current device (RCD) with the rating of above 10mA shall be incorporated in the fixed wiring according to the national rule.
- The appliance shall be installed in accordance with national wiring regulations.

6.1 Protections and safety control

- **Minutes delay for the compressor start-up**
At the beginning of energizing, 3-minutes delay should be taken to start the compressor. while after the stop of the compressor, 7-minutes delay should be taken to re-start the compressor.
- **Compressor discharge temperature protection**
When discharge temperature $>257^{\circ}\text{F}$, the compressor will stop.
- **Reverse phase protection relay**
 - The reverse phase protection relay will make the unit not start, when the power source is incorrectly connected.
 - The checking of phase order is just carried out at the first time of electrifying. If malfunction happens then the checking will be going on until the order of phase is right, and the E0 will be displayed on the board. If there is no problem in the first checking, then it will be omitted.
- **High pressure and low pressure protection**
When high pressure ≥ 638 Psi, and lower pressure ≤ 21 Psi, the unit will stop.

6.2 Electrical data

Tab.6-1

- 460V 3Ph~ 60Hz

Nominal ton	Model type	Type of flow	Compressor				Evaporator fan motor			Condenser fan motor		
			STC	RNC	IPT	Qty	RNC	IPT	Qty	RNC (each)	IPT (each)	Qty
20	C/O	Hor.	142	20.7	11.25	2	7.20	4.198	1	3.50	1.90	2
25	C/O	Hor.	147	21.4	12.94	2	9.40	5.723	1	4.30	2.75	2



NOTES

- STC: Starting Current (A) RNC: Running Current (A) IPT: Input Power (kW) Qty: Quantity
- These data are based on the following conditions. Evaporator Air Input Temperature 89.6°F DB, 73.4°F WB. Condenser Air Input Temperature 125.6°F DB.

6.3 Wiring provision

Field wiring

The units are internally wired at the factory according to generally accepted electrical technology.

Required field wiring

Main power wiring to the unit control wiring between the control center and the unit, and earth wiring are required in the field.

Required components

The following components are required: main power fuses, conduit coupling, and field supplied room thermostat.

Wire and fuse size selection for main power source

Wire and fuse sizes should be selected in accordance with national and standard, taking the designed maximum current shall be the total of the compressor maximum current, condenser fan motor current and evaporator fan motor current(refer to "electrical data").

Wire size between room thermostat and unit

The wire size between the room thermostat and the unit should be determined according to the following table, because the 24V power source is applied to the control circuit.

Tab.6-2

	Wiring length between room thermostat and unit(one way)				
	10m	15m	20m	30m	40m
Minimum wire size(mm ²)	0.5	0.5	0.75	0.75	1.0



NOTE

- Before connecting the device to the public low-voltage supply systems the permission of the electricity supplier is forcefully necessary.

6.4 Operating conditions

For proper performance, run the unit under the following temperature conditions:

Tab.6-3

Cooling operation	Outdoor temperature: 50°F to 125.6°F
	Room temperature: 62°F to 88°F
	Caution Room relative humidity less than 80%. If the unit operates in excess of this figure, the surface of the unit may attract condensation.

6.5 Main power supply

Tab.6-4

Model type		Unit main power	Main power switch	Fuse	Wires for Power supplies	Type of wires
20Tons	C/O	460V 3Ph~ 60Hz	75A	63A	3x16mm ² +2x10mm ²	3xUL1015 5AWG 2xUL1015 7AWG
25Tons	C/O	460V Ph~ 60Hz	90A	80A	3x25mm ² +2x10mm ²	3xUL1015 3AWG 2xUL1015 7AWG



NOTE

- The power supply designation is H07RN-F.

6.6 Control wiring

■ Power supply

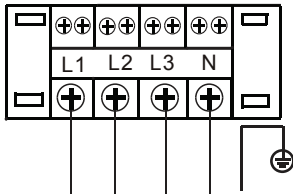

Fig. 6-1

Next wire joint also available

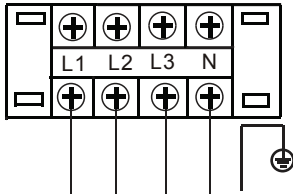
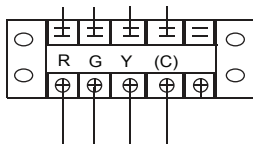

Fig. 6-2

■ To connect with wire controller

● For C/O Units



● For E/Heater+C Units

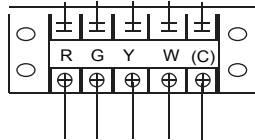

Suggestion: Choose a Intensity Thermostat, programmable or non-programmable.

Wiring please refer to the Owner's Manual of the thermostat.

■ Dial code settings

Set the dial code SW3 of PCB in unit's wire control box, After settings, please shut off the power supply and then repower, otherwise, the new settings function couldn't work.

- When SW3 has been set in "ON", please select KJR-12B wire controller;
- When SW3 has been set in "1", please select KJR-23B wire controller.

● For C/O Units

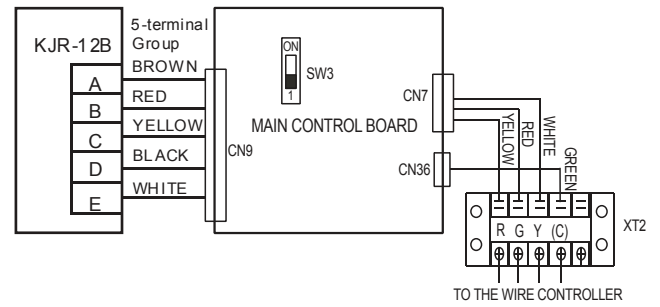

● For E/Heater+C Units

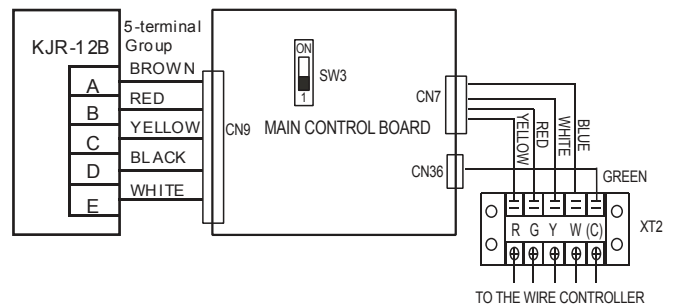

6.7 Error code

Type	Content	Code	Remarks
Normal	Standby	—	
Normal	Constraint cool	on	
Normal	Run	10.	
Error	Compressor phase sequence error or phase default	E0	
Error	Outdoor coil sensor in sys. A error	E1	
Error	Outdoor coil sensor in sys. B error	E2	
Error	Overcurrent protection of system A are active 3 times within one hour	E3	Unit shall be power off to recovery
Error	Overcurrent protection of system B are active 3 times within one hour	E4	Unit shall be power off to recovery
Error	Indoor coil sensor in sys. A error	E5	
Error	Indoor coil sensor in sys. B error	E6	
Error	High、 low pressure protection or discharge temperature protection of system A reached 3 times	E7	Unit shall be power off to recovery
Error	High、 low pressure protection or discharge temperature protection of system B reached 3 times	E8	Unit shall be power off to recovery
Error	Indoor sensor error	E9	
Error	Outdoor ambient sensor error	EA	
Error	Wire controller output error	Eb	
Error	EEPROM error	EE	
Protection	Overcurrent protection in sys.A	P0	
Protection	Overcurrent protection in sys.B	P1	
Protection	Overcurrent protection for indoor fan	P2	
Protection	Comprehensive protection for outdoor fan	P3	
Protection	Protection for Hi./Lo. pressure or exhaust temp. in sys.A	P4	Comprehensive protection in sys.A
Protection	Protection for Hi./Lo. pressure or exhaust temp. in sys.B	P5	Comprehensive protection in sys.B
Protection	Hi-pressure protection initiated in T2 evaporator stops the outdoor unit fan	P6	
Protection	Hi-pressure protection initiated in T2 evaporator stops the outdoor unit fan and compressor	P7	
Protection	Protection for condenser Hi-temp. in sys.A	P8	
Protection	Protection for condenser Hi-temp. in sys.B	P9	
Protection	Anti-freezing protection for evaporator in sys. A	Pc	
Protection	Anti-freezing protection for evaporator in sys. B	Pd	
Protection	Defrosting	dF	
Protection	Protection for outdoor temp	PA	

7. SPECIFICATION

7.1 Physical Data

Tab.7-1
460V 3Ph~ 60Hz

Nominal ton		20Tons	25Tons
Model type		C/O	C/O
Type of flow		Hor.	Hor.
Capacity	Cooling capacity(net) (Btu/h) ⁽¹⁾	240000	300000
	Heating capacity (Btu/h)	---	---
Performance	EER	10.9	10.7
Dimensions	Length(mm)	1670	2320
	Width(mm)	2192	2220
	Height(mm)	1247	1245
Net weight(kg)		670	895
Refrigerant type		R410A	R410A
Flow control		Piston	Capillary
Compressor	Quantity/Type	2/Scroll	2/Scroll
Outdoor coil	Rows	3	3+2
	Fins per inch	17	17
	Tube diameter(in.)	9/32	9/32
Indoor coil	Rows	4	4
	Fins per inch	19	16
	Tube diameter(in.)	9/32	5/16
Outdoor fan	Quantity used/diameter(mm)	2/750	2/800
	Type	Propeller	Propeller
	Drive type	Direct	Direct
	Quantity speeds	1	1
	Quantity motors/power(kW)	2/1.9	2/2.75
	Motor RPM	1150	1100
	Nominal total CFM	19600	24375
Indoor fan	Quantity used/model	1/SYD315R2-L	1/SYD355R2-L
	Type	FC Centrifugal	FC Centrifugal
	Drive type	Belt	Belt
	Quantity speeds	Variable sheave	Variable sheave
	Quantity motors/power(kW)	1/4.2(120Pa)	1/5.7(250Pa)
	Motor RPM	1730	1730
	Nominal total CFM ^(II)	8300(120Pa)	11500(250Pa)



NOTES

- ⁽¹⁾ Cooling capacities are rated at 95°F ambient DB, 80°F entering DB, 67°F entering WB.
- ^(II) Units are suitable for operation to ±20% of nominal CFM.

7.2 Parameter For Air Volume

- Parameter table for indoor unit air volume

BLOWER DRIVE OPTIONS							
UNIT MAIN POWER	MODEL TYPE	MOTOR			BLOWER		
		HP	RPM	PULLEY PITCH DIA. (INCH)	SPEED RANGE (RPM)		PULLEY PITCH DIA. (INCH)
					MINIMUM	MAXIMUM	
460V 3Ph~ 60Hz	20 Tons	7.3	1730	4.53~5.25	1081	1284	7.09
	25Tons	10	1730	4.53~5.25	925	1088	7.87

Example for selection process:

The following data are the rated design points for model 20 Ton rooftop:

Air flow(CFM)=9187cfm

External static pressure(ESP)=0.3in.w.g

Fan speed(RPM)=1098

Power input(W)=4847

The no. of turns (N) =1

To increase the ESP to 0.4in.w.g, but maintain the airflow rate at 9187cfm, please follow the steps below:

Step 1: Selection of new desired point.

From the table data, select the point that can meet both of the requirements (ESP = 0.4in.w.g and airflow rate(near or equal to) =9187cfm).

Step 2: Read Fan speed(RPM), Power input(W):

Air flow(CFM)=9260cfm

Fan speed(RPM)=1125

Power input(W)=5100

Step 3: Read number of turns for variable pitch pulley.

Similarly, use this RPM value to read the no. of turns (N) by referring to the table of 'Motor Variable Pitch Pulley Data'. The variable pitch pulley for motor shall be adjusted to this 'N' in order to achieve the desired point (ESP = 0.4in.w.g and airflow rate =9260cfm). For instance, from the table, no. of turns (N) =0.5 in order to get 9260cfm. First, adjust the motor pulley to 0 turns. Then, makes 0.5 turns on the pulley. Cross check the dimension 'X', which stands for regulation space of motor pulley. In this case, X = 1.5mm.

20 Tons (460V 3Ph~ 60Hz)

External static pressure(ESP)	N	0	0.25	0.5	0.75	1	1.25	1.5	1.75	2	2.25	2.5	2.75	3
	X	0.5	1	1.5	2	2.5	3	3.5	4	4.5	5	5.5	6	6.5
0	Fan speed(RPM)	1148	1135	1122	1109	1096	1082	1069	1056	1042	1028	1014	1000	983
	Power input(W)	6099	5892	5685	5477	5270	5063	4856	4654	4451	4219	3987	3810	3576
	Air flow (CFM)	10424	10282	10141	9999	9858	9716	9575	9449	9323	9200	9077	8884	8655
0.1	Fan speed(RPM)	1149	1136	1123	1110	1097	1084	1071	1057	1043	1029	1016	1002	984
	Power input(W)	5997	5787	5577	5366	5156	4946	4736	4534	4331	4102	3873	3686	3488
	Air flow (CFM)	10256	10113	9969	9826	9682	9539	9395	9266	9136	8996	8855	8665	8489
0.2	Fan speed(RPM)	1150	1136	1123	1110	1097	1084	1071	1057	1043	1030	1016	1002	985
	Power input(W)	5783	5586	5388	5191	4994	4796	4599	4397	4194	3968	3741	3544	3382
	Air flow (CFM)	9995	9851	9706	9562	9417	9273	9128	8995	8861	8703	8546	8358	8235
0.3	Fan speed(RPM)	1150	1137	1124	1111	1098	1085	1072	1058	1045	1031	1017	1003	987
	Power input(W)	5641	5442	5244	5046	4847	4649	4451	4235	4020	3809	3599	3550	3229
	Air flow (CFM)	9779	9631	9483	9335	9187	9039	8891	8731	8571	8422	8274	8331	7928
0.4	Fan speed(RPM)	1151	1138	1125	1112	1099	1086	1073	1060	1046	1032	1018	1005	989
	Power input(W)	5498	5299	5100	4900	4701	4502	4303	4074	3845	3651	3456	3555	3076
	Air flow (CFM)	9563	9412	9260	9109	8957	8806	8654	8467	8281	8141	8002	8305	7621
0.5	Fan speed(RPM)	1152	1139	1126	1113	1100	1086	1073	1060	1046	1032	1017	1006	992
	Power input(W)	5338	5139	4940	4741	4542	4343	4144	3921	3699	3494	3289	3051	2832
	Air flow (CFM)	9349	9188	9028	8867	8707	8546	8386	8217	8049	7899	7749	7488	7279
0.6	Fan speed(RPM)	1153	1140	1127	1113	1100	1087	1074	1060	1047	1033	1019	1004	990
	Power input(W)	5177	5006	4801	4599	4261	4052	3984	3763	3541	3352	3162	2910	2724
	Air flow (CFM)	9135	8980	8897	8800	8666	8540	8118	7947	7775	7621	7467	7151	6969
0.7	Fan speed(RPM)	1154	1137	1125	1112	1097	1084	1075	1061	1047	1033	1019	1003	990
	Power input(W)	4976	4798	4634	4395	4073	3857	3767	3545	3323	3136	2950	2699	2517
	Air flow (CFM)	8822	8644	8574	8429	8304	8157	7725	7540	7355	7193	7031	6737	6539
0.8	Fan speed(RPM)	1155	1137	1125	1113	1097	1084	1076	1061	1047	1033	1020	1003	991
	Power input(W)	4775	4589	4467	4190	3884	3662	3549	3327	3104	2921	2737	2487	2309
	Air flow (CFM)	8509	8309	8251	8058	7941	7774	7333	7133	6934	6765	6595	6324	6108
0.9	Fan speed(RPM)	1157	1141	1128	1115	1100	1087	1077	1063	1049	1035	1021	1006	993
	Power input(W)	4518	4343	4168	3923	3632	3395	3227	3003	2778	2590	2403	2166	1975
	Air flow (CFM)	8106	7901	7783	7620	7478	7293	6477	6260	6043	5841	5638	5356	5107
1.0	Fan speed(RPM)	1159	1145	1130	1117	1102	1089	1079	1065	1050	/	/	/	/
	Power input(W)	4261	4097	3869	3655	3379	3128	2905	2679	2452	/	/	/	/
	Air flow (CFM)	7702	7494	7316	7181	7014	6812	5622	5387	5152	/	/	/	/
1.1	Fan speed(RPM)	1161	1146	1133	1119	1105	1092	/	/	/	/	/	/	/
	Power input(W)	3890	3717	3487	3239	2952	2689	/	/	/	/	/	/	/
	Air flow (CFM)	6825	6588	6374	6198	6003	5733	/	/	/	/	/	/	/
1.2	Fan speed(RPM)	1163	1148	1136	1122	/	/	/	/	/	/	/	/	/
	Power input(W)	3518	3336	3105	2822	/	/	/	/	/	/	/	/	/
	Air flow (CFM)	5948	5682	5431	5214	/	/	/	/	/	/	/	/	/
1.3	Fan speed(RPM)	1163	1149	1135	/	/	/	/	/	/	/	/	/	/
	Power input(W)	3518	3276	2960	/	/	/	/	/	/	/	/	/	/
	Air flow (CFM)	5948	5553	5130	/	/	/	/	/	/	/	/	/	/
1.4	Fan speed(RPM)	1276	1262	/	/	/	/	/	/	/	/	/	/	/
	Power input(W)	4546	4243	/	/	/	/	/	/	/	/	/	/	/
	Air flow (CFM)	7459	6935	/	/	/	/	/	/	/	/	/	/	/
1.5	Fan speed(RPM)	1280	1267	/	/	/	/	/	/	/	/	/	/	/
	Power input(W)	3982	3457	/	/	/	/	/	/	/	/	/	/	/
	Air flow (CFM)	6465	5433	/	/	/	/	/	/	/	/	/	/	/
1.6	Fan speed(RPM)	1284	/	/	/	/	/	/	/	/	/	/	/	/
	Power input(W)	3417	/	/	/	/	/	/	/	/	/	/	/	/
	Air flow (CFM)	5471	/	/	/	/	/	/	/	/	/	/	/	/

Legend: X: Regulation Space of Motor Pulley (mm); N: Number of Turns; ESP: External Static Pressure (in.w.g)

25 Tons (460V 3Ph~ 60Hz)

External static pressure(ESP)	N	0	0.25	0.5	0.75	1	1.25	1.5	1.75	2	2.25	2.5	2.75	3	
	X	0.5	1	1.5	2	2.5	3	3.5	4	4.5	5	5.5	6	6.5	
0	Fan speed(RPM)	/	/	/	/	/	/	/	/	/	/	/	/	/	1172
	Power input(W)	/	/	/	/	/	/	/	/	/	/	/	/	/	8368
	Air flow (CFM)	/	/	/	/	/	/	/	/	/	/	/	/	/	13634
0.1	Fan speed(RPM)	/	/	/	/	/	/	/	/	/	/	/	/	/	1174
	Power input(W)	/	/	/	/	/	/	/	/	/	/	/	/	/	8191
	Air flow (CFM)	/	/	/	/	/	/	/	/	/	/	/	/	/	13419
0.2	Fan speed(RPM)	/	/	/	/	/	/	/	/	/	/	/	/	/	1188 1174
	Power input(W)	/	/	/	/	/	/	/	/	/	/	/	/	/	8028 7900
	Air flow (CFM)	/	/	/	/	/	/	/	/	/	/	/	/	/	13235 13095
0.3	Fan speed(RPM)	/	/	/	/	/	/	/	/	/	/	/	/	/	1189 1175
	Power input(W)	/	/	/	/	/	/	/	/	/	/	/	/	/	7802 7674
	Air flow (CFM)	/	/	/	/	/	/	/	/	/	/	/	/	/	12938 12800
0.4	Fan speed(RPM)	/	/	/	/	/	/	/	/	/	/	/	/	/	1185 1180 1176
	Power input(W)	/	/	/	/	/	/	/	/	/	/	/	/	/	7453 7450 7447
	Air flow (CFM)	/	/	/	/	/	/	/	/	/	/	/	/	/	12592 12549 12505
0.5	Fan speed(RPM)	/	/	/	/	/	/	/	/	/	1215	1185	1181	1176	
	Power input(W)	/	/	/	/	/	/	/	/	/	7350	7164	7155	7146	
	Air flow (CFM)	/	/	/	/	/	/	/	/	/	12552	12275	12208	12141	
0.6	Fan speed(RPM)	/	/	/	/	/	/	/	/	1225	1216	1186	1181	1177	
	Power input(W)	/	/	/	/	/	/	/	/	8405	7032	6874	6860	6845	
	Air flow (CFM)	/	/	/	/	/	/	/	/	12706	12210	11958	11867	11777	
0.7	Fan speed(RPM)	/	/	/	/	/	/	/	1230	1220	1216	1187	1183	1178	
	Power input(W)	/	/	/	/	/	/	/	6950	6846	6742	6607	6589	6571	
	Air flow (CFM)	/	/	/	/	/	/	/	12704	12377	11835	11597	11500	11402	
0.8	Fan speed(RPM)	/	/	/	/	/	/	1230	1225	1220	1217	1188	1184	1180	
	Power input(W)	/	/	/	/	/	/	8379	8203	7854	6452	6339	6318	6297	
	Air flow (CFM)	/	/	/	/	/	/	12654	12423	12048	11460	11237	11132	11028	
0.9	Fan speed(RPM)	/	/	/	/	/	1215	1210	1200	1200	1189	1185	1183	1181	
	Power input(W)	/	/	/	/	/	8155	8124	7923	7573	6195	6090	6062	6033	
	Air flow (CFM)	/	/	/	/	/	12362	12352	12092	11671	11140	10926	10773	10620	
1	Fan speed(RPM)	/	/	/	1220	1215	1214	1209	1200	1200	1189	1185	1182	1182	
	Power input(W)	/	/	/	8696	8497	7868	7868	7643	7292	5938	5841	5805	5769	
	Air flow (CFM)	/	/	/	12321	12063	12045	12050	11762	11294	10821	10615	10413	10212	
1.1	Fan speed(RPM)	/	/	1220	1218	1213	1210	1207	1199	1199	1188	1182	1181	/	
	Power input(W)	/	/	8383	8404	8195	6473	6463	6317	5952	5779	5693	5768	/	
	Air flow (CFM)	/	/	11957	11970	11681	11553	11509	11280	10792	10452	10300	10200	/	
1.2	Fan speed(RPM)	/	1220	1218	1215	1210	1208	1205	1197	1197	1188	1181	/	/	
	Power input(W)	/	8566	8077	8111	7892	6495	6475	6409	6029	5843	5768	/	/	
	Air flow (CFM)	/	12174	11596	11619	11299	11308	11215	11045	10536	10098	9999	/	/	
1.3	Fan speed(RPM)	/	1218	1215	1212	1208	1206	1203	1195	1191	1186	/	/	/	
	Power input(W)	/	8576	8216	8117	7892	6186	6316	5915	5870	5939	/	/	/	
	Air flow (CFM)	/	12402	11891	11681	11299	10418	10847	9838	10168	9105	/	/	/	
1.4	Fan speed(RPM)	1220	1215	1213	1210	1206	1201	1200	1188	1178	/	/	/	/	
	Power input(W)	8629	7946	7715	7484	7253	6250	6380	5979	5934	/	/	/	/	
	Air flow (CFM)	11462	11818	11374	10931	10487	10034	9605	9356	9025	/	/	/	/	
1.5	Fan speed(RPM)	1215	1211	1210	1209	1205	1201	1200	1189	/	/	/	/	/	
	Power input(W)	8342	8575	8809	7967	7126	6123	6253	5852	/	/	/	/	/	
	Air flow (CFM)	11076	11514	11952	11069	10187	9733	9304	9055	/	/	/	/	/	
1.6	Fan speed(RPM)	1206	1204	1201	1201	1200	1196	1189	/	/	/	/	/	/	
	Power input(W)	8055	8011	7967	7791	6999	5996	6126	/	/	/	/	/	/	
	Air flow (CFM)	10689	10656	10622	10489	9886	9433	9004	/	/	/	/	/	/	
1.7	Fan speed(RPM)	1200	1200	1196	1196	1189	1186	/	/	/	/	/	/	/	
	Power input(W)	5571	5615	5659	5835	6627	5624	/	/	/	/	/	/	/	
	Air flow (CFM)	8441	8474	8508	8642	9244	8791	/	/	/	/	/	/	/	
1.8	Fan speed(RPM)	1186	1184	1184	1184	1180	1180	/	/	/	/	/	/	/	
	Power input(W)	7310	7266	7222	7046	6254	5251	/	/	/	/	/	/	/	
	Air flow (CFM)	9406	9373	9339	9205	8603	8150	/	/	/	/	/	/	/	

Legend: X: Regulation Space of Motor Pulley (mm); N: Number of Turns; ESP: External Static Pressure (in.w.g)

7.3 Capacity Data (460V 3Ph~ 60Hz)

■ Cooling capacity — 20 Tons (460V 3Ph~ 60Hz)

Air Flow (CFM)		5400				8300				10400					
Ent (DB)	(°F)	75	80	85	90	75	80	85	90	75	80	85	90		
Ambient Temperature	85	61	TC	216.3	218.9	228.7	241.5	222.2	226.9	236.6	249.5	224.6	230.3	244.8	256.0
			SC	174.0	206.2	221.9	234.4	183.6	219.0	229.6	242.1	193.4	223.5	237.5	248.4
			PI	21929.5	21998.6	22553.9	22569.6	22249.6	22289.7	22570.0	22657.7	22076.4	22553.9	22643.0	22731.3
		67	TC	242.3	245.3	248.0	251.4	249.5	251.3	252.7	254.4	252.6	254.5	256.0	257.9
			SC	138.6	169.1	198.2	228.8	144.8	175.6	207.8	238.4	147.2	180.5	214.3	248.1
			PI	23125.3	23264.6	23447.9	23653.3	23694.4	23814.4	23886.5	23975.4	23897.7	24169.7	24258.6	24330.8
		73	TC	256.0	260.9	264.1	267.4	258.9	262.5	267.4	270.4	262.2	265.7	268.8	272.1
			SC	95.7	128.2	154.8	180.5	97.5	131.1	158.3	183.4	99.3	132.3	161.0	190.1
			PI	24423.2	24508.5	24680.6	24736.1	24516.2	24591.7	24808.3	24863.8	24439.8	24747.2	24849.2	24959.2
	95	61	TC	202.8	207.7	217.5	231.9	205.4	214.2	227.1	239.9	212.6	217.5	233.6	246.4
			SC	165.9	198.2	211.0	225.1	175.6	205.8	218.1	230.4	185.4	211.0	226.6	239.1
			PI	21297.9	21437.3	21992.6	22008.3	21608.4	21728.4	22008.7	22096.4	21720.5	21992.6	22081.7	22170.0
		67	TC	227.1	230.3	233.6	238.3	236.6	240.0	241.5	243.1	244.8	246.6	248.2	249.5
			SC	132.3	162.8	193.4	223.9	137.8	170.8	203.1	236.7	193.1	231.2	233.2	246.5
			PI	22493.7	22703.3	22886.5	23092.0	23053.1	23553.0	23625.2	23714.1	23841.8	23908.4	23997.2	24069.4
		73	TC	249.6	252.7	255.8	259.2	251.4	254.2	258.1	262.5	253.7	257.0	260.2	261.8
			SC	91.5	123.3	151.9	178.9	93.4	127.5	156.0	185.4	95.2	129.7	159.7	190.1
			PI	23791.6	23947.1	24119.2	24174.8	23874.9	24030.4	24247.0	24302.5	24083.9	24185.9	24287.9	24397.9
	105	61	TC	188.7	193.6	203.3	219.6	195.2	200.1	216.3	226.1	198.5	206.6	224.5	239.1
			SC	158.3	187.9	197.3	213.1	169.3	194.2	209.9	219.4	179.1	200.5	217.8	232.0
			PI	23997.6	24137.0	24692.2	24708.0	24308.1	24428.1	24708.4	24796.1	24420.1	24692.2	24781.3	24869.6
		67	TC	216.3	219.6	224.5	226.1	218.0	222.8	229.3	232.6	229.3	232.6	235.8	239.1
			SC	125.3	156.3	187.0	219.2	144.3	164.4	198.2	209.4	135.8	172.4	207.8	239.2
			PI	24441.6	24651.2	24834.4	25039.9	25001.0	25200.9	25273.1	25361.9	25489.6	25556.3	25645.1	25717.3
73		TC	245.6	247.2	248.8	250.5	248.8	250.5	252.1	255.3	252.1	253.7	255.3	257.0	
		SC	86.9	118.1	147.9	175.8	88.9	122.3	152.9	183.8	90.5	126.2	157.0	188.5	
		PI	26639.5	26795.0	26967.1	27022.6	26722.8	26878.2	27094.8	27150.3	26931.7	27033.7	27135.7	27245.7	
115	61	TC	180.3	186.8	203.0	219.3	185.1	194.9	211.1	227.4	190.0	201.4	219.3	235.5	
		SC	159.4	181.5	197.3	213.0	168.8	189.4	205.1	220.9	177.1	195.7	213.0	228.8	
		PI	26728.7	26868.1	27423.4	27439.1	27039.2	27159.2	27439.5	27527.2	27151.3	27423.4	27512.5	27600.8	
	67	TC	194.1	197.4	199.0	202.3	195.8	200.6	203.9	207.1	207.1	210.4	215.3	218.5	
		SC	121.1	140.9	171.5	202.4	127.6	149.5	182.9	207.2	151.1	173.9	208.0	209.6	
		PI	27172.7	27382.3	27565.5	27771.0	27732.1	27900.0	28004.2	28093.1	28220.8	28287.4	29487.4	29559.6	
	73	TC	220.1	223.4	226.6	228.3	226.6	229.9	231.5	233.1	231.5	233.1	234.8	236.4	
		SC	73.2	104.2	134.9	165.0	75.0	109.7	140.6	171.5	78.9	113.0	147.1	181.2	
		PI	29793.8	29949.3	30121.4	30176.9	29877.1	30032.6	30249.1	30304.6	30086.0	30188.0	30290.0	30400.0	
118.4	61	TC	176.7	183.2	199.4	215.7	181.5	191.3	207.5	223.8	186.4	197.8	215.7	231.9	
		SC	155.8	177.9	193.7	209.4	165.2	185.8	201.5	217.3	173.5	192.1	209.4	225.2	
		PI	27099.7	27239.1	27794.4	27810.1	27410.2	27530.2	27810.5	27898.2	27522.3	27794.4	27883.5	27971.8	
	67	TC	193.2	196.3	197.7	200.8	194.9	199.4	202.6	205.6	206.2	209.3	214.0	217.0	
		SC	120.2	139.8	170.2	200.9	126.7	148.4	181.6	205.7	150.2	172.8	196.0	208.1	
		PI	27543.7	27753.3	27936.5	28142.0	28103.1	28196.0	28375.2	28464.1	28591.8	28658.4	29858.4	29930.6	
	73	TC	216.5	219.8	223.0	224.7	223.0	226.3	227.9	229.5	227.9	229.5	231.2	232.8	
		SC	69.6	100.6	131.3	161.4	71.4	106.1	137.0	167.9	75.3	109.4	143.5	177.6	
		PI	30160.2	30315.6	30487.8	30543.3	30243.4	30398.9	30615.5	30671.0	30452.4	30554.4	30656.4	30400.0	

Notes:

- All capacities are net and have considered indoor fan heat.
- TC=Total Capacity. (Unit:1000Btu/h)
- SC=SensibleCapacity. (Unit:1000Btu/h)
- PI=Power input (unit:W)
- Different air volume in the above table, need to adjust in the field

■ Cooling capacity — 25 Tons (460V 3Ph~ 60Hz)

Air Flow (CFM)			8500				9500				11500				
Ent (DB)		(°F)	75	80	85	90	75	80	85	90	75	80	85	90	
Ambient Temperature	85	61	TC	266.8	272.4	278.2	284.0	274.0	279.8	285.7	291.7	280.8	286.7	292.7	298.9
			SC	231.0	235.9	241.0	246.1	247.0	252.3	257.6	263.1	262.0	267.6	273.2	279.0
			PI	30182.3	30382.3	30454.6	30582.4	30472.3	30672.3	30744.6	30872.4	30762.3	30962.3	31034.6	31162.4
		67	TC	298.0	304.3	310.7	317.2	301.0	307.3	313.8	320.4	303.8	310.1	316.6	323.3
			SC	172.0	219.1	265.0	301.3	178.0	229.9	284.2	310.6	186.5	262.4	280.5	315.3
			PI	30682.3	30882.3	30954.6	31082.4	30972.3	31172.3	31244.6	31372.4	31262.3	31462.3	31534.6	31662.4
		73	TC	309.3	315.7	322.4	329.1	310.3	316.8	323.4	330.2	311.0	317.5	324.2	331.0
			SC	108.3	161.4	198.0	237.6	109.8	163.6	205.0	256.1	111.5	169.4	220.2	260.3
			PI	31258.6	31463.0	31536.6	31667.0	31568.6	31773.0	31846.6	31977.0	31878.6	32083.0	32156.6	32287.0
	95	61	TC	246.5	251.7	257.1	262.5	254.3	259.6	265.1	270.8	261.8	267.3	272.9	278.7
			SC	220.8	225.5	230.3	235.2	237.0	242.1	247.2	252.5	252.5	258.3	263.3	268.9
			PI	29950.1	30132.3	30199.4	30316.5	30200.1	30382.3	30449.4	30566.5	30450.1	30632.3	30699.4	30816.5
		67	TC	273.8	279.5	285.4	291.4	278.3	289.6	295.7	301.9	294.0	300.0	306.5	312.9
			SC	166.0	213.6	258.2	297.8	174.8	226.1	274.2	300.1	182.5	257.3	270.2	310.3
			PI	32159.7	32359.7	32432.0	32559.8	32449.7	32649.7	32722.0	32849.8	32749.7	33000.0	33022.0	33149.8
		73	TC	306.5	312.9	319.5	326.2	307.3	313.7	320.3	327.0	309.0	315.5	322.1	328.9
			SC	104.8	152.6	193.0	233.8	107.0	155.9	200.0	251.6	107.8	158.1	208.7	251.1
			PI	34048.6	34257.7	34332.7	34466.1	34358.6	34567.7	34642.7	34776.1	34668.6	34877.7	34952.7	35086.1
	105	61	TC	225.8	230.6	235.5	240.5	234.0	239.0	244.1	249.3	239.0	244.1	249.3	254.6
			SC	210.5	215.0	219.6	224.4	227.0	231.9	236.8	241.9	222.5	227.3	232.1	237.1
			PI	31937.5	32119.7	32186.8	32303.9	32187.5	32369.7	32436.8	32553.9	32437.5	32619.7	32686.8	32803.9
		67	TC	265.3	270.9	276.6	282.4	271.8	277.5	283.4	289.3	276.0	281.8	287.8	293.8
			SC	158.0	205.1	254.0	278.3	167.3	219.4	269.2	284.1	174.5	234.9	265.0	280.8
			PI	34647.1	34847.1	34919.4	35047.2	34937.1	35137.1	35209.4	35337.2	35237.1	35437.1	35509.4	35637.2
73		TC	299.0	305.3	311.7	318.2	301.0	307.3	313.8	320.4	302.5	308.9	315.3	322.0	
		SC	99.8	147.1	186.7	223.1	102.0	153.1	192.5	248.6	103.3	152.9	199.0	246.3	
		PI	37478.2	37695.2	37772.3	37910.2	37788.2	38005.2	38082.3	38220.2	38098.2	38315.2	38392.3	38530.2	
115	61	TC	198.3	202.7	207.2	211.8	205.5	210.1	214.7	219.4	213.3	218.0	222.8	227.7	
		SC	193.5	197.8	202.2	206.7	197.5	201.9	206.4	211.0	207.5	212.1	216.8	221.6	
		PI	34074.9	34257.1	34324.2	34441.3	34324.9	34507.1	34574.2	34691.3	34574.9	34757.1	34824.2	34941.3	
	67	TC	235.8	240.9	246.2	251.6	240.5	245.8	251.1	256.6	246.5	251.7	257.4	263.0	
		SC	140.8	190.1	237.5	242.7	150.3	202.6	245.5	250.8	159.0	217.4	250.5	258.6	
		PI	36784.5	36984.5	37056.8	37184.6	37074.5	37274.5	37346.8	37474.6	37374.5	38000.8	38100.8	38174.6	
	73	TC	280.5	286.6	292.7	299.0	282.8	288.9	295.1	301.4	284.5	290.6	296.9	303.3	
		SC	87.5	135.4	174.7	204.1	89.3	142.4	177.7	235.1	91.3	141.6	185.0	230.6	
		PI	41654.8	41878.8	41955.4	42096.2	41964.8	42188.8	42265.4	42406.2	42274.8	42498.8	42575.4	42716.2	
118	61	TC	195.6	200.0	204.5	209.1	202.8	207.4	212.0	216.7	210.6	215.3	220.1	225.0	
		SC	190.8	195.1	199.5	204.0	194.8	199.2	203.7	208.3	204.8	209.4	214.1	218.9	
		PI	34671.1	34853.3	34920.4	35037.5	34921.1	35103.3	35170.4	35287.5	35171.1	35353.3	35420.4	35537.5	
	67	TC	233.1	238.2	243.5	248.9	237.8	243.1	248.4	253.9	243.8	249.0	254.7	260.3	
		SC	138.1	187.4	234.8	240.0	147.6	199.9	242.8	248.1	156.3	214.7	247.8	255.9	
		PI	37380.7	37580.7	37653.0	37780.8	37670.7	37870.7	37943.0	38070.8	37970.7	38171.0	38243.0	38370.8	
	73	TC	277.8	283.9	290.0	296.3	280.1	286.2	292.4	298.7	281.8	287.9	294.2	300.6	
		SC	84.8	132.7	172.0	201.4	86.6	139.7	175.0	232.4	88.6	138.9	182.3	227.9	
		PI	42398.3	42617.7	42696.6	42836.3	42708.3	42927.7	43006.6	43146.3	43018.3	43237.7	43316.6	43456.3	

Notes:

- 1.All capacities are net and have considered indoor fan heat.
- 2.TC=Total Capacity. (Unit:1000Btu/h)
- 3.SC=SensibleCapacity. (Unit:1000Btu/h)
- 4.different air volume in the above table,need to adjust in the field

8. START-UP

■ Before starting unit

- Is the unit properly located and level with the proper clearance?
- Is the duct work correctly sized, run, taped, insulated, and weatherproofed with proper unit arrangement? See Ductwork Installation section.
- Is the wiring properly sized and run according to the unit wiring diagram?
- Are all the wiring connections, including those in the unit, tight?
- Has the unit been properly grounded and fused with the recommended fuse size? See Wiring Data.
- Have the air conditioning systems been checked at the service ports for charge and leak tested if necessary?
- Does the condenser fan and indoor blower fan free without rubbing, and are they tight on the shafts?
- Are all covers and access panels in place to prevent air loss and safety hazards?

■ Starting the unit in the cooling mode

■ Voltage

With the unit operating, check the line voltage of the unit. The voltage should be within the range shown on the unit nameplate.

If low voltage is encountered, check the size and length of the supply line from the main disconnect to the unit. The line may be undersized for the length of the run.

■ Cooling shut down

Place the system selector in the OFF position or reset thermostat at a setting above room temperature.

Do not de-energize the main power disconnect except when unit is to be serviced.

9. MAINTENANCE

■ Regular maintenance

Some regular maintenance have been carry on by user, includes: change the one-time dust filter, clean casing, wash condenser and replace a new belt, as well as do some test for the equipment.

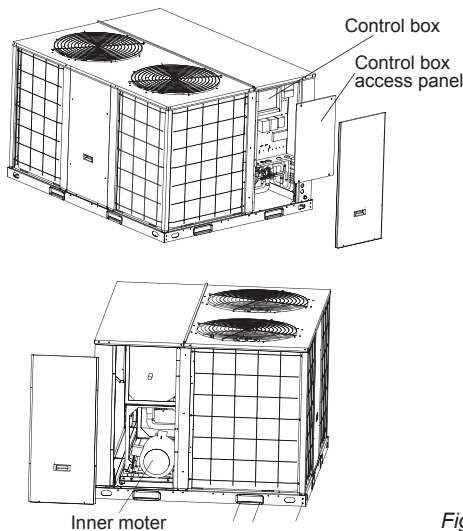

Fig.9-1



WARNING

At least 1m flame resistant layer must be laid at the end of the air duct internal surface.

■ Regulating belt of tension

Refer to Fig.9-3, loose 2 bolts, and move the electric motor to adjust belt tension.

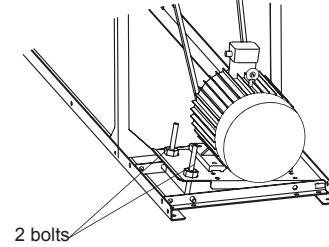

The two bolts are used for precision adjustment .

Fig.9-3

■ Belt tension is measured by belt tension indicator

- Calculate the deflection, $\text{deflection} = A/64$.
- Measure the belt deflection force, the force should be between the values shown in Tab.9-2

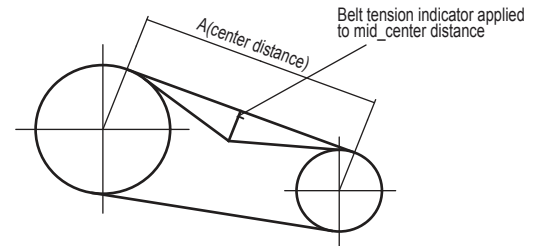

Fig.9-4

Tab.9-1

Nominal ton	A (mm)
20	580
25	480

Tab.9-2

Belt section	For required to deflection		
	Small pulley diameter (mm)	Newton(N)	Kilogram-force(kgf)
SPA	80 to132	25 to 35	2.5 to 3.6



NOTE

The belt which is too tight or too loose may generate noise and be harmful to the unit.

- If you use air filter accessories provided by the manufacturer, please dismantle the air filter as the following steps.

- Twist of screws and get out the plate.
- Pull out the filter along the supporting slot.

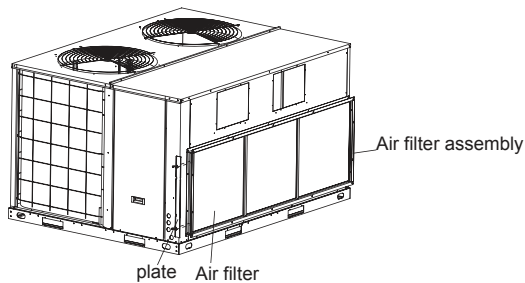

Fig.9-5

- Clean the air filter (Vacuum cleaner or fresh water may be used to clean the air filter. If the dust accumulated too much, please use soft brush and mild detergent to clean and dry out in cool place).

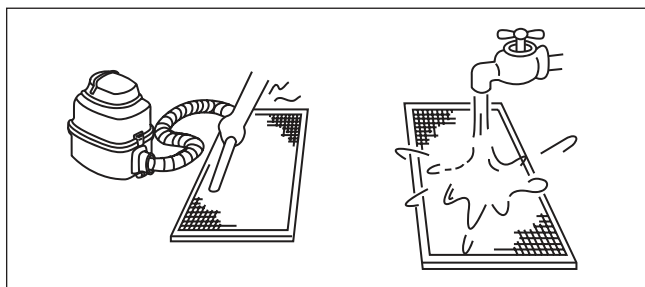

Fig.9-6

- The air-in side should face up when using vacuum cleaner.
- The air-in side should face down when using water.



CAUTION

Do not dry out the air filter under direct sunshine or heat.

- Re-install the air filter
- Condenser coil
Unfiltered air circulates through the unit's condenser coil can cause the coil's surface to become clogged with dust, etc. Clean the coil, vertically (i.e., with the fins), and stroke the coil surface with a soft brush. Be sure to keep all vegetation away from the condenser coil area.
- Maintenance performed by serviceman.
To keep your unit operating safely and efficiently, the manufacturer recommends that a qualified serviceman check the entire system at least once each year and any other time that you feel one is needed. Your serviceman should examine these areas of your unit:
 - Filters
 - Motors and drive system components
 - Economizer gaskets (for possible replacement)
 - Safety controls (for mechanical cleaning)
 - Electrical components and wiring (for possible replacement and connection tightness)
 - Condensate drain (for cleaning)
 - Unit duct connections (to see that they are physically sound and sealed to the unit casing)
 - Unit mounting support (for structural integrity)
 - The unit (for obvious unit deterioration)



CAUTION

- Do not operate the unit without the evaporator fan access panel in place. Reinstall the access panel after performing any maintenance. Operating the unit without the access panel may result in severe personal injury or death.
- This unit is not intended for use by persons (including children) with reduced physical, sensory or mental capabilities, or lack of experience and knowledge, unless they have been given supervision or instruction concerning use of the appliance by a person responsible for their safety. Children should be supervised to ensure that they do not play with the unit.
- Disconnect the power supply before cleaning and maintenance.
- The unit shall be installed in accordance with national wiring regulations.



DISPOSAL: Do not dispose this product as unsorted municipal waste. Collection of such waste separately for special treatment is necessary.

- Do not dispose of electrical appliances as unsorted municipal waste, use separate collection facilities.
- Contact you local government for information regarding the collection systems available.
- If electrical appliances are disposed of in landfills or dumps, hazardous substances can leak into the groundwater and get into the food chain, damaging your health and well-being.



Importado por: **INTENSITY AIR, S. A. DE C. V.**

RFC: IAI-100609-SRA.

Río Amacuzac #1125, Col. Valle Ote., CP. 66269

San Pedro Garza García, Nuevo León, México.

Note: Product specifications change from time to time as product improvements and developments are released and may vary from those in this document.