

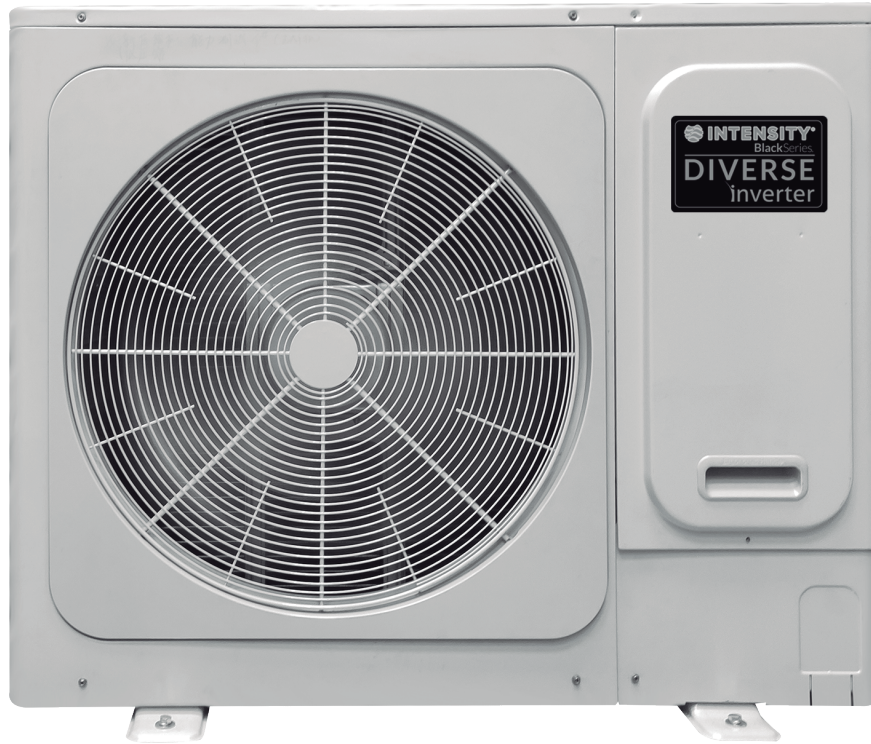

INTENSITY[®]
AIR CONDITIONING
BlackSeries.



OUTDOOR UNIT DIVERSE inverter

IVRF-CD28KC-3, IVRF-CD36KC-3, IVRF-CD42KC-3, IVRF-CD48KC-3,
IVRF-CD56KC-3, IVRF-CD60KC-3

OPERATION AND INSTALLATION MANUAL



CONTENTS

OPERATION MANUAL	01
1 BEFORE OPERATING	01
2 OPERATION	02
3 MAINTENANCE AND REPAIR	03
4 TROUBLESHOOTING	04
5 CHANGE INSTALLATION SITE	09
6 DISPOSAL	09
INSTALLATION MANUAL	10
1 PRECAUTIONS	10
2 ABOUT THE PACKING BOX	11
3 ABOUT THE OUTDOOR UNIT	11
4 PREPARATIONS BEFORE INSTALLATION	12
5 OUTDOOR UNIT INSTALLATION	16
6 ELECTRICAL WIRING	20
7 CONFIGURATION	23
8 TEST RUNNING	24
9 PRECAUTIONS ON REFRIGERANT LEAKAGE	25
10 TURN OVER TO CUSTOMER	25

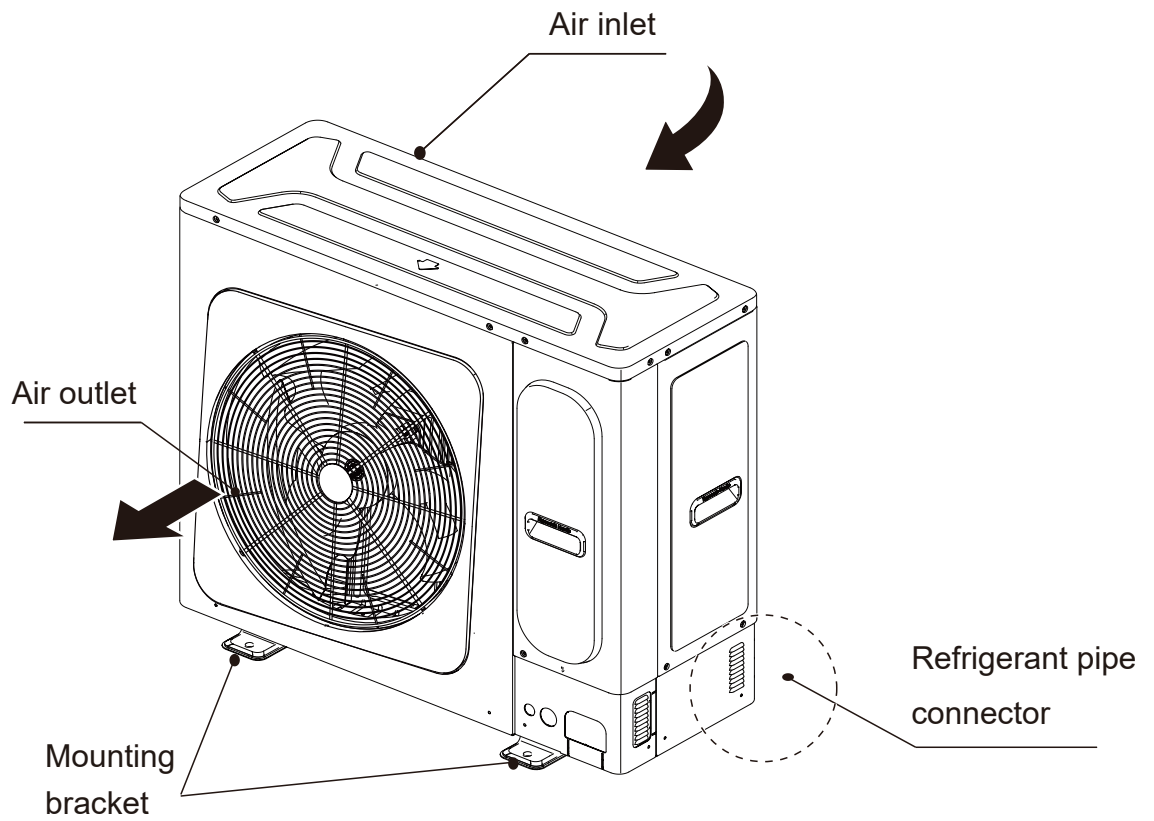

NOTE

All the pictures in this manual are for explanation purpose only. They may be slightly different from the air conditioner you purchased (depend on model). The actual shape shall prevail.

The units 28-56 kBTu/h comply with IEC 61000-3-12.

OPERATION MANUAL

1. BEFORE OPERATING

To prevent injury to the user or other people and property damage, the following instructions must be followed. Incorrect operation due to ignoring of instructions may cause harm or damage.

1.1 Overview

The safety precautions listed here are divided into two categories. either case, important safety information is listed which must be carefully.



WARNING

Failure to observe a warning may result in death. The appliance shall be installed in accordance with national wiring regulations.



WARNING

Failure to observe a warning may result in injury or damage to the equipment.

1.2 Important safety information



WARNING

This appliance can be used by children aged from 8 years and above and persons with reduced physical, sensory or mental capabilities or lack of experience and knowledge if they have been given supervision or instruction concerning use of the appliance in a safe way and understand the hazards involved.

Children shall not play with the appliance.

Cleaning and user maintenance shall not be made by children without supervision.

This appliance is not intended for use by persons (including children) with reduced physical, sensory or mental capabilities, or lack of experience and knowledge, unless they have been given supervision or instruction concerning use of the appliance by a person responsible for their safety.

Children should be supervised to ensure that they do not play with the appliance.

The split units shall only be connected to an appliance suitable for the same refrigerant.

The units 28-56 kBtu/h are split unit air conditioners, complying with split unit requirements of this International Standard, and must only be connected to the units that have been confirmed as complying to corresponding split unit requirements of this International Standard.

Ask your dealer for installation of the air conditioner.

Incomplete installation performed by yourself may result in a water leakage, electric shock, and fire.

Ask your dealer for improvement, repair, and maintenance.

Incomplete improvement, repair, and maintenance may result in a water leakage, electric shock, and fire.

In order to avoid electric shock, fire or injury, please turn off the power supply and call your dealer for instructions if you detect any abnormality such as smell of fire.

Never let the indoor unit or the remote controller get wet.

It may cause an electric shock or a fire.

Never press the button of the remote controller with a hard, pointed object.

The remote controller may be damaged.

Never replace a fuse with that of wrong rated current or other wires when a fuse blows out.

Use of wire or copper wire may cause the unit to break down or cause a fire.

It is not good for your health to expose your body to the air flow for a long time.

Do not insert fingers, rods or other objects into the air inlet or outlet.

When the fan is in operation, it will cause injury.

Never use a flammable spray, such as hair spray or lacquer paint, near the unit.

It may cause a fire.

Never touch the air outlet or the horizontal blades while the swing flap is in operation.

Fingers may become caught or the unit may break down.

Never put any objects into the air inlet or outlet.

Objects touching the fan at high speed can be dangerous.

Never inspect or service the unit by yourself.

Ask a qualified service person to perform this work.

Do not dispose this product as unsorted municipal waste. Collection of such waste separately for special treatment is necessary.

Do not dispose of electrical appliances as unsorted municipal waste, use separate collection facilities.

Contact your local government for information regarding the connection systems available.



If electrical appliances are disposed of in landfills or dumps, hazardous substances can leak into the groundwater and get into the food chain, damaging your health and well-being.

To prevent refrigerant leak, contact your dealer.

When the system is installed and runs in a small room, it is required to keep the concentration of the refrigerant, if by any chance coming out, below the limit. Otherwise, oxygen in the room may be affected, resulting in a serious accident.

The refrigerant in the air conditioner is safe and normally does not leak.

If the refrigerant leaks in the room, contact with a fire of a burner, a heater or a cooker may result in a harmful gas.

Turn off any combustible heating devices, ventilate the room, and contact the dealer where you purchased the unit.

Do not use the air conditioner until a service person confirms that the portion where the refrigerant leaks is repaired.



CAUTION

Do not use the air conditioner for other purposes.

In order to avoid any quality deterioration, do not use the unit for cooling precision instruments, food, plants, animals or works of art.

Before cleaning, be sure to stop the operation, turn the breaker off or pull out the supply cord.

Otherwise, an electric shock and injury may result.

In order to avoid electric shock or fire, make sure that an earth leak detector is installed.

Be sure the air conditioner is grounded.

In order to avoid electric shock, make sure that the unit is grounded and that the earth wire is not connected to gas or water pipe, lightning conductor or telephone earth wire.

In order to avoid injury, do not remove the fan guard of the outdoor unit.

Do not operate the air conditioner with a wet hand.
An electric shock may happen.

Do not touch the heat exchanger fins.
These fins are sharp and could result in cutting injuries.

Do not place items which might be damaged by moisture under the indoor unit.
Condensation may form if the humidity is above 80%, the drain outlet is blocked or the filter is polluted.

After a long use, check the unit stand and fitting for damage.
If damaged, the unit may fall and result in injury.

To avoid oxygen deficiency, ventilate the room sufficiently if equipment with burner is used together with the air conditioner.

Arrange the drain hose to ensure smooth drainage.
Incomplete drainage may cause wetting of the building, furniture etc.

Never touch the internal parts of the controller.
Do not remove the front panel. Some parts inside are dangerous to touch, and a machine trouble may happen.

Never expose little children, plants or animals directly to the air flow.
Adverse influence to little children, animals and plants may result.

Do not allow a child to mount on the outdoor unit or avoid placing any object on it.
Falling or tumbling may result in injury.

Do not operate the air conditioner when using a room fumigation - type insecticide.
Failure to observe could cause the chemicals to become deposited in the unit, which could endanger the health of those who are hypersensitive to chemicals.

Do not place appliances which produce open fire in places exposed to the air flow from the unit or under the indoor unit.
It may cause incomplete combustion or deformation of the unit due to the heat.

Do not install the air conditioner at any place where flammable gas may leak out.
If the gas leaks out and stays around the air conditioner, a fire may break out.

When the combination ratio of IDUs exceeds 100%, the output capacity of the system may decrease.

When the combination ratio of IDUs is greater than or equal to 120%, in order to ensure the capacity of the machine, and then try to open the indoor units at different time.

The outdoor unit window-shades should be periodic cleaning in case of being jammed.
This window-shapes is heat dissipation outlet of components, if being jammed will cause the components shorten their service life spans because of overheated for a long time.

The temperature of refrigerant circuit will be high, please keep the interconnection cable away from the copper tube.

The sound pressure level is below 56 dB(A).
This appliance is intended to be used by expert or trained users in shops, in light industry and on farms, or for commercial use by lay persons.

2. OPERATION

2.1 Operation range

Use the system in the following temperature for safe and effective operation. The operation range for the air conditioner is shown as Table 2-1.

Table 2-1

Model		28/36/42/48/56/60kbtu/h
Cooling	Indoor temperature	17°C to 32°C
	Outdoor temperature	-5°C to 55°C
Heating	Indoor temperature	0°C to 30°C
	Outdoor temperature	-15°C to 27°C
Dehumidification	Indoor temperature	12°C to 32°C
	Outdoor temperature	-5°C to 55°C



NOTE

- If the above operating conditions cannot be met, the safety protection function may be triggered and the air conditioner may malfunction.
- When the unit operates in "cooling" mode in a relatively humid environment (relative humidity higher than 80%), condensation may occur on the surface of the IDU and water may drip. In this case, turn the wind deflector to the maximum air outlet position and set the fan speed to "High".

2.2 Operation and performance

2.2.1 Operating system

Run

Press the "switch" button on the controller.
Result: The running light turns on and the system starts to run.

Repeatedly press the mode selector on the controller to select the required operation mode.

Stop

Press the "switch" button on the controller again.
Result: The running light is now off, and the system stops running.

Adjust

Refer to the user manual for the controller on how to set the required temperature, fan speed and air flow direction.



NOTE

- To protect this unit, please turn on the main power supply 12 hours before you start to operate this unit.
- Once the unit has stopped running, do not disconnect the power immediately. Wait for at least 10 minutes.

2.2.2 Cooling and heating operation

The indoor units in the air conditioner can be controlled separately, but the indoor units in the same system cannot operate in the heating and cooling modes at the same time.

When the cooling and heating operation conflict with each other, the indoor unit which are running in cooling or fan mode would stop and there will be standby or no priority displayed on the control panel. Those indoor units which are running on heating mode will run continuously.

If the air conditioner administrator has set running mode, then the air conditioner cannot run in any mode other than the presented. Standby or no priority will be displayed on the control panel.

2.2.3 Features of heating operation

About heating capacity

Once the unit starts, it takes some time for the room temperature to rise, as the unit uses a hot air circulation system to heat the room.

The indoor fan motor will automatically stop running so as to prevent cold air from coming out of the indoor unit when the heating operation starts. This process will take some time, which depends on the indoor and outdoor temperature. This is not a malfunction.

When there is a drop in the external temperature, the heating capacity decreases. If this happens, please use another heating equipment and unit at the same time. (Make sure the room is well ventilated if you are using an equipment that produces fire.) Do not place any equipment that may produce a fire where the air outlets of the unit are or below the unit itself.

And need to perform the following operations to prevent the heating capacity from dropping or prevent cold air from coming out of the system.

Defrost operation

In the heating operation, as the outdoor temperature decreases, frost may be formed on the heat exchanger in the outdoor unit, making it more difficult for the heat exchanger to heat up the air. The heating capacity decreases, and a defrosting operation needs to be performed on the system in order for the system to provide sufficient heat to the indoor unit. At this point, the indoor unit will show the defrost operation on the control panel.



NOTE

- The motor in indoor unit will continue running for 20~30 seconds to remove residual heat when the indoor unit receives shutdown command during heating operation.
- If the air conditioner malfunction occurs because of disturb, please disconnect the power from the air conditioner, then turn on it again.

2.2.4 About power cut

If there is a power outage while the unit is running, the unit will automatically restart its operation when the power supply resumes.

Mishandling in operation

If mishandling happens, please disconnect the power from the system and then reconnect it after a few minutes.

2.2.5 Four-minute protection feature

A protection feature prevents the air conditioner from being activated for approximately 4 minutes when it restarts immediately after operation.

2.2.6 Protection Equipment

This protection equipment will enable the air conditioner to stop when the air conditioner is to be directed running compulsively.

When the protection equipment is activated, the operation indicator still lights while the air conditioner is not running. But the check Indicator Lights.

The protection equipment may be activated in following conditions:

Cooling

- The air inlet or air outlet of outdoor unit is blocked.
- Strong wind is Continuously blowing to the air outlet of the outdoor unit.

Heating

- Too much dust and rubbish adhere to the dust filter in the indoor unit.
- The air outlet of indoor unit is choked.



NOTE

- When the protection equipment starts, please shut down the manual power switch, and restart operation after problem is solved.

3. MAINTENANCE AND REPAIR



WARNING

- When the fuse melts, do not use any unspecified fuse or other wire to replace the original fuse. The use of electrical wires or copper wires may cause the unit to malfunction or cause a fire.
- Do not insert fingers, sticks, or other items into the air inlet or outlet. Do not remove the fan mesh cover. When the fan rotates at a high speed, it may cause bodily injury.
- It is very dangerous to check the unit when the fan is rotating.
- Make sure you turn off the main switch before any maintenance work begins.
- Do check the supporting and base structure of the unit for any damages after a long period of use. The unit may drop and cause personal injury if there is any damage.



NOTE

- Do not check or repair the unit on your own. Please get relevant professionals to conduct any check or repairs.
- Do not use substances like gasoline, diluent, and chemical dust cloth to wipe the operations panel of the controller. This may remove the surface layer of the controller. If the unit is dirty, immerse a cloth in diluted and neutral detergent, squeeze it dry, and then use it to clean the panel. Finally, wipe it with a dry cloth.

3.1 Maintenance after unit has been shut down for a long period

For example, in early summer or winter.

- Check and remove all objects that may clog the air inlets and outlets of the indoor and outdoor units.

- Clean the air filter and external shell of the unit. Please contact the installation or maintenance personnel. The installation/operation manual of the indoor unit includes maintenance tips and cleaning procedures. Make sure that the clean air filter is installed in its original position. Check and remove all objects that may clog the air inlets and outlets of the indoor and outdoor units.
- Turn on the main power supply 12 hours before this unit is operated in order to ensure that the unit runs smoothly. The user interface is displayed once the power is turned on.

For example, at the end of winter or summer.

- Run the indoor unit in the fan mode for about half a day to dry the internal parts of the unit.
- Turn off the power supply.
- Clean the air filter and external shell of the unit. Please contact the installation or maintenance personnel to clean the air filter and external shell of the indoor unit. The installation/operation manual of the specialized indoor unit includes maintenance tips and cleaning procedures. Make sure that the clean air filter is installed in its original position.

3.2 About the Refrigerant

This product contains fluorinated greenhouse gases as stipulated in the Kyoto Protocol. Do not discharge the gas into the atmosphere.

Refrigerant Type: R410A

GWP Value: 2088

Based on the applicable law, the refrigerant must be checked regularly for leakages. Please contact the installation personnel for more information.



WARNING

- The refrigerant in the air conditioner is relatively safer, and usually does not leak. If the refrigerant leaks, and comes in contact with burning objects in the room, it will produce harmful gases.
- Shut down any flammable heating device, ventilate the room and contact the agent of the unit immediately.
- Do not use the air conditioner again until the maintenance personnel has confirmed that the refrigerant leakage has been completely resolved.

3.3 After-sales service and warranty

3.3.1 Warranty period

This product contains the warranty card that was completed by the agent during installation. The customer must check the completed warranty card and keep it properly.

If you need to repair the air conditioner during the warranty period, please contact the agent and provide the warranty card.

When you request the agent for assistance, please remember to state:

- Complete model name of the air conditioner.
- Date of installation.
- Details on the fault symptoms or errors, and any defects.



WARNING

- Do not attempt to modify, dismantle, remove, reinstall or repair this unit, as the improper dismantling or installation may result in electric shock or fire. Please contact the agent.
- If the refrigerant accidentally leaks, make sure that there is no fire around the unit. The refrigerant itself is completely safe, non-toxic and non-flammable, but it will produce toxic gases when it accidentally leaks and comes in contact with flammable substances generated by existing heaters, and burning devices in the room. You must get a qualified maintenance personnel to verify that the point of leakage has been repaired or rectified before you restore the operations of the unit.

3.4 Shorter maintenance and replacement cycle

In the following situations, the "maintenance cycle" and "replacement cycle" may be shortened.

The unit is used in the following situations:

- Temperature and humidity fluctuations are outside the normal ranges.
- Large power fluctuations (voltage, frequency, waveform distortion etc.) (must not use the unit if the power fluctuations exceed the allowed range).
- Frequent collisions and vibrations.
- The air may contain dust, salt, harmful gas or oil such as sulphite and hydrogen sulphide.
- Frequent on and off of unit or operating time is too long (in places where the air conditioning is on for 24 hours a day).

4. TROUBLESHOOTING

4.1 Troubles and causes of air conditioner

If one of the following malfunctions occur, stop operation, shut off the power, and contact with your dealer.

- The operation lamp is flashing rapidly (twice every second)
This lamp is still flashing rapidly after turn off the power and turn on again.
- Remote controller receives malfunction or the button does not work well.
- A safety device such as a fuse, a breaker frequently actuates.
- Obstacles and water enter the unit.
- Water leaks from indoor unit.
- Other malfunctions.

If the system does not properly operate except the above mentioned cases or the above mentioned malfunctions is evident, investigate the system according to the following procedures. (see in Table 4-1)

Table 4 -1

Symptoms	Causes	Solution
Unit does not start	<ul style="list-style-type: none"> • Power failure. • Power switch is off. • Fuse of power switch may have burned. • Batteries of remote controller exhausted or other problem of controller. 	<ul style="list-style-type: none"> • Wait for the comeback of power. • Switch on the power. • Relocation: • Replace the batteries or check the controller.
Air flowing normally but completely can't cooling	<ul style="list-style-type: none"> • Temperature is not set correctly. • Be in 3 minutes protection of compressor. 	<ul style="list-style-type: none"> • Set the temperature properly. • Wait.
Units start or stop frequently	<ul style="list-style-type: none"> • Refrigerant is too little or too much. • Air or no concreting gas in the refrigerating circuit. • Compressor is malfunction. • Voltage is too high or too low. • System circuit is blocked. 	<ul style="list-style-type: none"> • Check leakage, and rightly recharge refrigerant. • Vacuum and recharge refrigerant. • Maintenance or change compressor. • Install manostat. • Find reasons and solution.
Low cooling effect	<ul style="list-style-type: none"> • Outdoor unit and indoor unit heat exchanger is dirty. • The air filter is dirty. • Inlet/outlet of indoor/outdoor units is blocked. • Doors and windows are open • Sunlight directly shine. • Too much heat resource. • Outdoor temp. is too high. • Leakage of refrigerant or lack of refrigerant. 	<ul style="list-style-type: none"> • Clean the heat exchanger. • Clean the air filter. • Eliminate all dirties and make air smooth. • Close doors and windows. • Make curtains in order to shelter from sunshine. • Reduce heat source. • AC cooling capacity reduces (normal). • Check leakage and rightly recharge refrigerant.
Low heating effect	<ul style="list-style-type: none"> • Outdoor temperature is lower than 7°C • Doors and windows not completely closed. • Leakage of refrigerant or lack of refrigerant. 	<ul style="list-style-type: none"> • Use heating device. • Close doors and windows. • Check leakage and rightly recharge refrigerant.

4.2 Troubles and causes of remote controller

Before asking for serving or repairing , check the following points.

(see in Table 4-2)

Table 4-2

Symptoms	Causes	Solution
The fan speed can not be changed.	Check whether the MODE indicated on the display is "AUTO".	When the automatic mode is selected, the air conditioner will automatically change the fan speed.
	Check whether the MODE indicated on the display is "DRY".	When dry operation is selected, the air conditioner automatically change the fan speed. The fan speed can be selected during "COOL" , "FAN ONLY", and "HEAT"
The remote controller signal is not transmitted even when the ON/OFF button is pushed.	Check whether the batteries in the remote controller are exhausted.	The power supply is off.
The TEMP. indicator does not come on.	Check whether the MODE indicated on the display is FAN ONLY.	The temperature cannot be set during FAN mode.
The indication on the display disappears after a lapse of time.	Check whether the timer operation has come to an end when the TIMER OFF is indicated on the display.	The air conditioner operation will stop up to the set time.
The TIMER ON indicator goes off after a lapse of certain time.	Check whether the timer operation is started when the TIMER ON is indicated on the display.	Up to the set time, the air conditioner will automatically start and the appropriate indicator will go off.
No receiving tone sounds from the indoor unit even when the ON/OFF button is pressed.	Check whether the signal transmitter of the remote controller is properly directed to the infrared signal receiver of the indoor unit when the ON/OFF button is pressed.	The air conditioner operation will stop up to the set time.

4.3 Error code: Overview

Table 4-3 (28/36/42/48/56kBTu/h)

No.	Fault or protection type	Recovery mode	Error code
1	Communication fault between main control board and communication terminals block	Recoverable	C0
2	Communication error between indoor and outdoor unit	Recoverable	E2
3	Outdoor heat exchanger temperature sensor (T3) error or outdoor ambient temperature sensor (T4) error	Recoverable	E4
4	Input voltage protection	Recoverable	E5
5	DC fan protection	Recoverable	E6
6	EEPROM Error	Unrecoverable	E9
7	Compressor parameters mismatch	Unrecoverable	E.9.
8	E6 errors occur more than six times in an hour.	Unrecoverable	Eb
9	PFC fault	Unrecoverable	EF
10	Refrigerant radiator temperature sensor error	Recoverable	EH
11	Cooling ambient temperature lower than -15 °C	Recoverable	EP
12	DC bus voltage protection	Recoverable	F1
13	Indoor unit and outdoor unit program mismatch	Recoverable	HF
14	L(L0/L1) fault occurs three times in one hour.	Unrecoverable	H4
15	The number of online indoor units have decreased or increased .	Recoverable	H7
16	IPM module protection	Recoverable	L0
17	DC bus low voltage protection	Recoverable	L1
18	DC bus high voltage protection	Recoverable	L2
19	Other drive failures	Recoverable	L3
20	MCE error	Recoverable	L4
21	Zero speed protection	Recoverable	L5
22	Compressor phase sequence error	Recoverable	L7
23	Protection for compressor speed change > 15Hz	Recoverable	L8
24	Protection for the difference between the setting speed and the running speed of the compressor > 15Hz	Recoverable	L9
25	Radiator surface high temperature protection	Recoverable	PL
26	System high pressure protection	Recoverable	P1
27	System low pressure protection	Recoverable	P2
28	Overcurrent protection	Recoverable	P3
29	Discharge temperature T5 protection	Recoverable	P4
30	Outdoor condenser temperature sensor (T3) protection	Recoverable	P5
31	Typhoon protection	Recoverable	P8
32	T2 indoor unit evaporator temperature protection	Recoverable	PE
33	Poor reversing of four-way valve	Recoverable	P9

Table 4-4 (60kBTu/h)

No.	Fault or protection type	Recovery mode	Error code
1	Communication error between main chip and compressor drive chip	Recoverable	H0
2	Communication error between indoor and outdoor units	Recoverable	E2
3	Actual compressor frequency differs from target frequency by more than 15Hz protection	Recoverable	L9
4	Abnormal power supply voltage	Recoverable	E5
5	DC fan motor error	Recoverable	E6
6	EEPROM Error	Unrecoverable	E9
7	compressor parameter mismatching	Unrecoverable	E.9.
8	E6 error appears 6 times in 1 hour(power off to recover)	Unrecoverable	Eb
9	PFC feedback resistance off	Unrecoverable	EF
10	TL sensor error	Recoverable	EH
11	Cooling Mode T4 low temperature protection	Recoverable	EP
12	DC bus voltage(PN voltage)<200VDC in 5 sec.	Recoverable	F1
13	L(L0/L1) fault appears 3 times in a hour(power off to recover)	Unrecoverable	H4
14	Qty. of indoor units increasement or decreasement error	Recoverable	H7
15	Module protection	Recoverable	L0
16	DC bus low voltage protection	Recoverable	L1
17	DC bus high voltage protection	Recoverable	L2
18	Other driving error	Recoverable	L3
19	MCE error	Recoverable	L4
20	Zero speed protection	Recoverable	L5
21	Phase sequence error	Recoverable	L7
22	Compressor frequency variation greater than 15Hz within one second protection	Recoverable	L8
23	T3, T4 temperature sensor error	Recoverable	E4
24	Radiator surface temperature protection	Recoverable	PL
25	System high pressure protection	Recoverable	P1
26	System low pressure protection	Recoverable	P2
27	Overcurrent protection	Recoverable	P3
28	T5 discharge temperature protection	Recoverable	P4
29	Outdoor condenser temperature(T3) protection	Recoverable	P5
30	T2 Indoor evaporator temperature protection	Recoverable	PE
31	Four-way valve protection	Recoverable	P9

If the problem remains, please contact the distributor or Intensity's air conditioner customer service center, and provide info about the product model and the fault details.

Display Function Instruction:

1. When stand by, LED displaying the amount of indoor units online which communicate with outdoor units.
2. When operation, LED displaying frequency value of compressor.
3. When defrost, LED displaying "dF".

4.4 Following symptoms are not air conditioner troubles

Symptom 1: The system does not operate

- The air conditioner does not start immediately after the ON/OFF button on the remote controller is pressed.
If the operation lamp lights, the system is in normal condition. To prevent overloading of the compressor motor, the air conditioner starts 3 minutes after it is turned on.
- If the operation lamp and the "PRE-DEF indicator(cooling and heating type) or fan only indicator(cooling only type)" light, it means you choose the heating model, When just starting, if the compressor has not started, the indoor unit appears "anti cold wind" protection because the air outlet temperature is too low .

Symptom 2: Change into the fan mode during cooling mode

- In order to prevent the indoor evaporator frosting, the system will change into fan mode automatically, restore to the cooling mode after soon.
- When the room temperature drops to the set temperature, the compressor goes off and the indoor unit changes to fan mode; when the temperature rises up, the compressor starts again. It is same in the heating mode.

Symptom 3: White mist comes out of a unit

Symptom 3.1: Indoor unit

- When humidity is high during cooling operation If the interior of an indoor unit is extremely contaminated, the temperature distribution inside a room becomes uneven. It is necessary to clean the interior of the indoor unit. Ask your dealer for details on cleaning the unit. This operation requires a qualified service provider

Symptom 3.2: Indoor unit, outdoor unit

- When the system is changed over to heating operation after defrost operation Moisture generated by defrost becomes steam and is exhausted.

Symptom 4: Noise of air conditioner's cooling

Symptom 4.1: Indoor unit

- A continuous low "shah" sound is heard when the system is in cooling operation or at a stop.
When the drain pump (optional accessories) is in operation, this noise is heard.
- A "pishi-pishi" squeaking sound is heard when the system stops after heating operation.
Expansion and contraction of plastic parts caused by temperature change make this noise.

Symptom 4.2: Indoor unit, outdoor unit

- A continuous low hissing sound is heard when the system is in operation.
This is the sound of refrigerant gas flowing through both indoor and outdoor units.
- A hissing sound which is heard at the start or immediately after stopping operation or defrost operation.
This is the noise of refrigerant caused by flow stop or flow change.

Symptom 4.3: Outdoor unit

- When the tone of operating noise changes, the noise is caused by the change of frequency.

Symptom 5: Dust comes out of the unit

- When the unit is used for the first time in a long time, it is because dust has gotten into the unit.

Symptom 6: The units can give off odors

- The unit can absorb the smell of rooms, furniture, cigarettes, etc., and then emit it again.

Symptom 7: The outdoor unit fan does not spin.

- During operation. The speed of the fan is controlled in order to optimize product operation.

5. CHANGE INSTALLATION SITE

Please contact the agent to dismantle and reinstall all the units. You need specialized skills and technology to move the units.

6. DISPOSAL

This unit uses hydrogen fluorocarbons. Please contact the agent when you want to dispose this unit. Based on the requirements of the law, the collection, transportation and disposal of refrigerants must be in accordance with the regulations governing the collection and destruction of hydrofluorocarbons.

INSTALLATION MANUAL

1. PRECAUTIONS

- Ensure that all Local, National and International regulations are satisfied.
- Read this "PRECAUTIONS " carefully before Installation. The precautions described below include the important items regarding safety. Observe them without fail.
- After the installation work, perform a trial operation to check for any problem.
- Follow the Operation Manual to explain how to use and maintain the unit to the customer.
- Turn off the main power supply switch (or breaker) before maintaining the unit.
- Ask the customer that the Installation Manual and the Operation Manual should be kept together.



CAUTION

New Refrigerant Air Conditioner Installation

THIS AIR CONDITIONER ADOPTS THE NEW HFC REFRIGERANT(R410A)WHICH DOES NOT DESTROY OZONE LAYER.

The characteristics of R410A refrigerant are: hydrophilic, oxidizing membrane or oil, and its pressure is approx. 1.6 times higher than that of refrigerant R22. Accompanied with the new refrigerant, refrigerating oil has also been changed. Therefore, during installation work, be sure that water, dust, former refrigerant, or refrigerating oil does not enter the refrigerating cycle.

To prevent charging an incorrect refrigerant and refrigerating oil, the sizes of connecting sections of charging port of the main unit and installation tools are changed from those for the conventional refrigerant.

Accordingly the exclusive tools are required for the new refrigerant (R410A):

For connecting pipes, use new and clean piping designed for R410A, and please care so that water or dust does not enter. Moreover, do not use the existing piping because there are problems with pressure-resistance force and impurity in it.



CAUTION

Do not connect the appliance from main power supply.

This unit must be connected to the main power supply by means of a switch with a contact separation of at least 3 mm. The installation fuse must be used for the power supply line of this conditioner.



WARNING

If the supply cord is damaged, it must be replaced by the manufacturer or its service agent or a similarly qualified person in order to avoid a hazard.

An all-pole disconnection switch having a contact separation of at least 3mm in all poles should be connected in fixed wiring. The appliance shall be installed in accordance with national wiring regulations.

The temperature of refrigerant circuit will be high, please keep the interconnection cable away from the copper tube.

An all-pole disconnection device which has at least 3mm separation distance in all pole and a residual current device (RCD) with the rating of above 10mA shall be incorporated in the fixed wiring according to the national rule.

The power cord type designation is H05RN-R/H07RN-F or above.

Ask an authorized dealer or qualified installation professional to install or maintain the air conditioner.

Inappropriate installation may result in water leakage, electric shock or fire.

Turn off the main power supply switch or breaker before attempting any electrical work.

Make sure all power switches are off. Failure to do so may cause electric shock.

Connect the connecting cable correctly.

If the connecting cable is connected in a wrong way, electric parts may be damaged.

When moving the air conditioner for the installation into another place, be very careful not to enter any gaseous matter other than the specified refrigerant into the refrigeration cycle.

If air or any other has is mixed in refrigerant, the gas pressure in the refrigeration cycle becomes abnormally high and it may resultantly causes pipe burst and injuries on persons.

Do not modify this unit by removing any of the safety guards or by by-passing any of the safety interlock switches.

Exposure of unit to water or other moisture before installation may cause a short-circuit of electrical parts.

Do not store it in a wet basement or expose to rain or water.

After unpacking the unit, examine it carefully if there are possible damage.

Do not install in a place that might increase the vibration of the unit.

To avoid personal injury (with sharp edges), be careful when handling parts.

Perform installation work properly according to the Installation manual.

Inappropriate installation may result in water leakage, electric shock or fire.

When the air conditioner is installed in a small room, provide appropriate measures to ensure that the concentration of refrigerant leakage occur in the room does not exceed the critical level.

Install the air conditioner securely in a location where the base can sustain the weight adequately.

Perform the specified installation work to guard against an earthquake.

If the air conditioner is not installed appropriately, accidents may occur due to the falling unit.

If refrigerant gas has leaked during the installation work, ventilate the room immediately.

If the leaked refrigerant gas comes in contact with fire, noxious gas may generate.

After the installation work, confirm that refrigerant gas does not leak.

If refrigerant gas leaks into the room and flows near a fire source, such as a cooking range, noxious gas might generate.

Electrical work must be performed by a qualified electrician in accordance with the Installation manual. Make sure the air conditioner uses an exclusive power supply.

An insufficient power supply capacity or inappropriate installation may cause fire.

Use the specified cables for wiring connect the terminals securely fix. To prevent external forces applied to the terminals from affecting the terminals.

Be sure to provide grounding.

Do not connect ground wires to gas pipes, water pipes, lightning rods or ground wires for telephone cables.

Conform to the regulations of the local electric company when wiring the power supply.

Inappropriate grounding may cause electric shock.

Do not install the air conditioner in a location subject to a risk of exposure to a combustible gas.

If a combustible gas leaks, and stays around the unit, a fire may occur.

Required tools for installation work

- 1) Philips screw driver
- 2) Hole core drill (65mm)
- 3) Spanner
- 4) Pipe cutter
- 5) Knife
- 6) Reamer
- 7) Gas leak detector
- 8) Tape measure
- 9) Thermometer
- 10) Mega-tester
- 11) Electro circuit tester
- 12) Hexagonal wrench
- 13) Flare tool
- 14) Pipe bender
- 15) Level vial
- 16) Metal saw
- 17) Gauge manifold (Charge hose: R410A special requirement)
- 18) Vacuum pump (Charge hose: R410A special requirement)
- 19) Torque wrench
 - 1/4(17mm)16N•m (1.6kgf•m)
 - 3/8(22mm)42N•m (4.2kgf•m)
 - 1/2(26mm)55N•m (5.5kgf•m)
 - 5/8(15.9mm)120N•m (12.0kgf•m)
- 20) Copper pipe gauge adjusting projection margin
- 21) Vacuum pump adapter

Equipment complying with IEC 61000-3-12.

2. ABOUT THE PACKING BOX

2.1 Delivery and moving

Delivery

Remember the following:

- At the time of delivery, check the unit for any damage. Report any damage immediately to the carrier's claim agent.
- As far as possible, transport the packaged unit to its final installation site to prevent damage during the handling process.
- Take note of the following items when transporting the unit:



Fragile. Handle with care.



Keep the unit with its front facing upwards so as not to damage it.

- Select the unit transportation path in advance.

Moving

- Since the gravity center of the unit is not at its physical center, so please be careful when lifting it with a sling.
- Never hold the inlet of the outdoor unit to prevent it from deforming.
- Do not touch the fan with hands or other objects.
- Do not lean it more than 45°, and do not lay it sidelong.

2.2 Attached fittings

	NAME	SHAPE	QUANTITY
INSTALLATION FITTINGS	1. Outdoor unit operation and installation manual		1
	2. Water outlet pipe connector		1
	3. Rubber wire ring (36/42/48/56kBTu/h)		2
	4. Network matching wires		2
	5. Connecting pipe (56/60kBTu/h)		1



NOTE

- Check if any accessory in the above figure is missing. All the accessories must be kept properly.
- All the fittings should be Intensity fittings.
- Wired/Remote controller — purchase separately.
- Outlet sealant — purchase separately.
- All the figures in the manual explain only the general appearance and dimensions of the unit. The air conditioner you purchased may not be completely consistent with the appearance and functions listed in the figures. Please refer to the actual product.

3. About the outdoor unit

3.1 Outdoor unit combination ratio

Table 3-1

Outdoor Unit (kBTu/h)	Capacity of ODU (horsepower)	Number of IDUs	Combination Ratio
28	2.5	1~4	45%~130%
36	3	1~6	45%~130%
42	4	1~7	45%~130%
48	5	1~8	45%~130%
56	6	1~9	45%~130%
60	7	1~9	45%~130%

Capacity conversion table

Table 3-2

Capacity (kBTu/h)	Capacity (horsepower)	Capacity (kBTu/h)	Capacity (horsepower)
6	0.6	27	3
7	0.8	30	3.2
9	1	34	3.6
12	1.25	38	4
15	1.6	47	5
19	2	54	6
24	2.5		



CAUTION

The total capacity of the IDUs, measured in horsepower, must not exceed 130% of the capacity of the ODU.
When the combination ratio of IDUs exceeds 100%, the output capacity of the system may decrease.

3.2 Outdoor unit stop valve size

Table 3-3

MODEL (kBTu/h)	Piping side	The size of outdoor unit stop valve(mm)	
		Gas Side	Liquid Side
28		Φ15.9	Φ9.5
36		Φ15.9	Φ9.5
42		Φ15.9	Φ9.5
48		Φ15.9	Φ9.5
56		Φ19.1	Φ9.5
60		Φ19.1	Φ9.5

4. PREPARATIONS BEFORE INSTALLATION

4.1 Choose and prepare the installation site

4.1.1 Placement consideration

Please keep away from the following place, or malfunction of the machine may be caused:

- There is combustible gas leakage.
- There is much oil (including engine oil) ingredient.
- There is salty air surrounding (near the coast)
- There is caustic gas (the sulfide, for example) existing in the air (near a hot spring)
- A place the heat air expelled out from the outdoor unit can reach your neighbor's window.
- A place that the noise interferes your neighbors every day life.
- A place that is too weak to bear the weight of the unit
- Uneven place.
- Insufficient ventilation place.
- Near a private power station or high Frequency equipment.
- Install indoor unit, outdoor unit, power cord and connecting wire at least 1m away from TV set or radio to prevent noise or picture interference.
- Install the unit in the place that can offer enough space for installation and maintenance. Don't install it in the place that has a high requirement for noise, such as the bed room.



CAUTION

- Install the outdoor unit at a place where discharge air is not blocked.
- When an outdoor unit is installed in a place that is always exposed to a strong wind like a coast or on a high story of a building, secure a normal fan operation by using a duct or a wind shield.
- When installing the outdoor unit in a place that is constantly exposed to a strong wind such as the upper stairs or rooftop of a building, apply the windproof measures referring to the following examples.

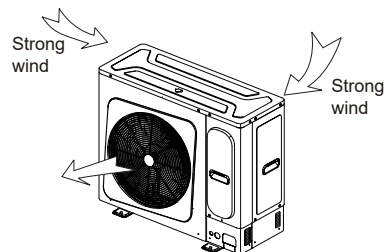

Fig.4-1

Supposing the wind direction during the operation season of the discharge port is set at right angle to the wind direction.

4.1.2 Installation space (Unit: mm)

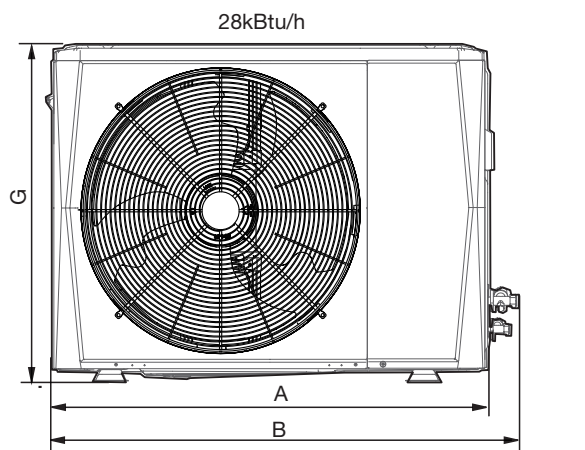

Fig.4-2

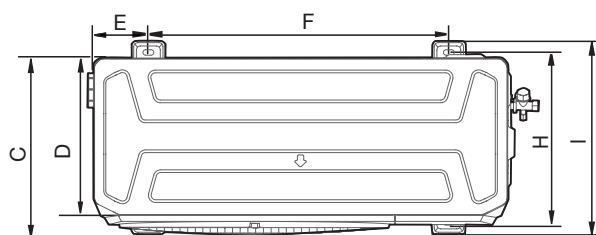

Fig.4-3

36/42/48/56kBTu/h

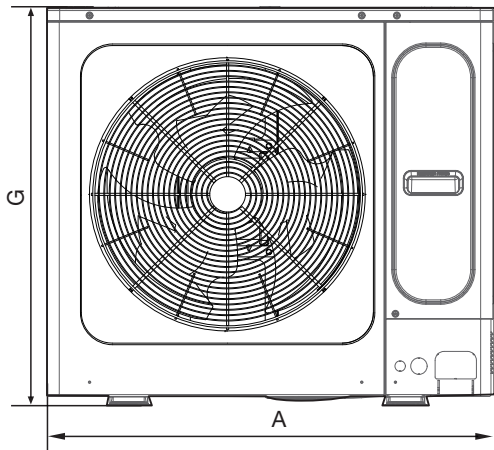

Fig.4-4

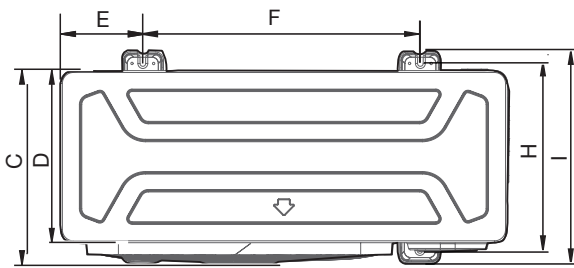

Fig.4-5

60kBTu/h

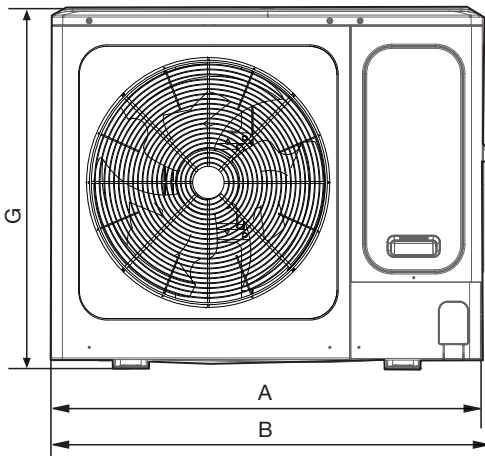

Fig.4-6

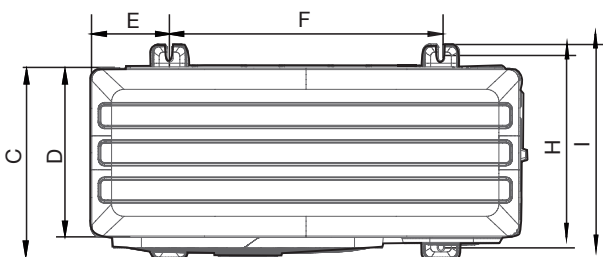

Fig.4-7

Table 4-1 (unit: mm)

Model	28	36/42/48/56	60
A	910	950	1040
B	982	/	1053
C	390	406	452
D	345	360	410
E	120	175	191
F	663	590	656
G	712	840	865
H	375	390	463
I	426	440	523
Drawing No.	Fig.4-2, Fig.4-3	Fig.4-4, Fig.4-5	Fig.4-6, Fig.4-7

■ Single unit installation

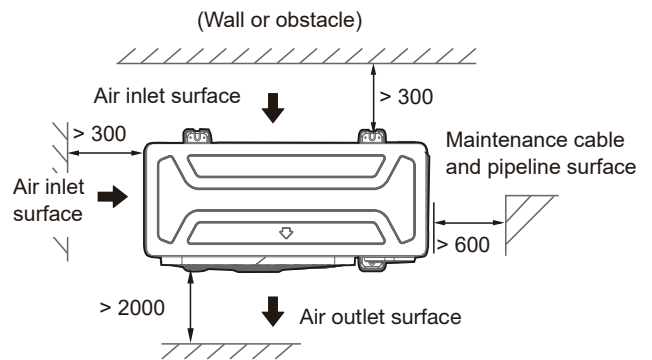

Fig.4-8

■ Parallel connect the two units or above

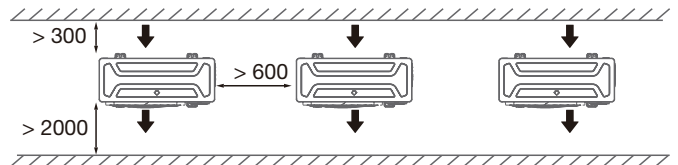

Fig.4-8

■ Parallel connect the front with rear sides

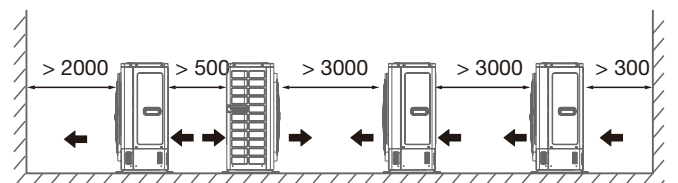

Fig.4-9



CAUTION

- Keep a distance of 2000mm or more between the unit and the wall surface when the discharge port faces to the wall of the building.

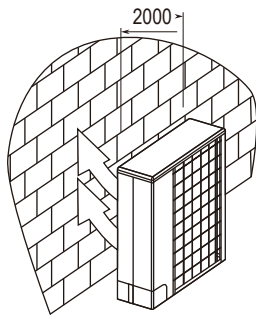

Fig.4-10

4.2 Select and prepare the refrigerant piping

4.2.1 Connect method

Table 4-2

Pipe definition	Pipe connect position	Code
Main pipe	The pipe between outdoor unit to the first branch of indoor unit.	L1
The main pipes of indoor unit	The pipe after the first branch do not directly connect with the indoor unit.	L2, L3 (≤1m)
The branch pipes of indoor unit	The pipe after the branch connect with the indoor unit.	a,b,c, d,e,f
Branch header	The branch components connect with the main pipe, the branch pipe and the the main pipe of indoor unit.	Refer to Table 5-2

- The number of IDU no more than 6 (the connection method)

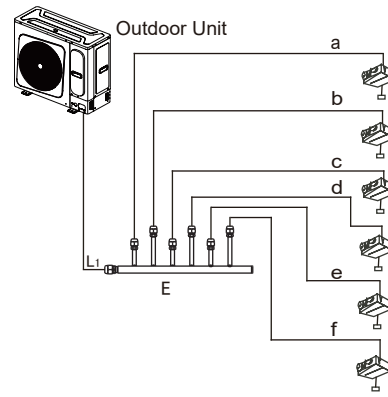

Fig. 4-11

- The number of IDU more than 6 (the connection method)

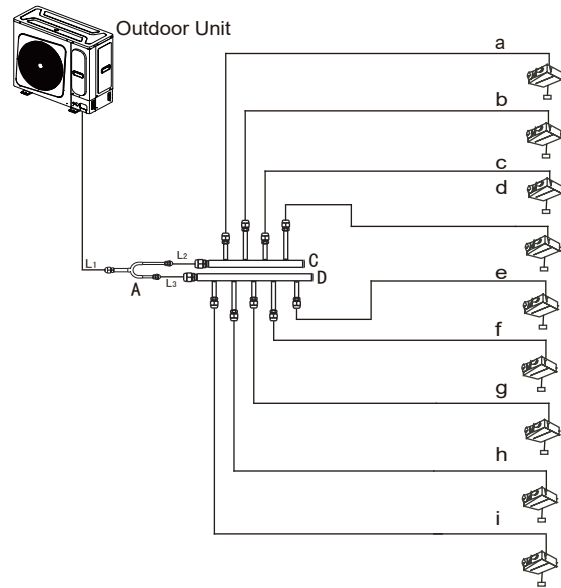

Fig.4-12

4.2.2 Allowable length and height difference for refrigerant piping

- When the outdoor unit connects more than one indoor unit

Allowable length and height difference for refrigerant piping

table 4-3

		Pimitted value	Piping	
Pipe Length	Total Pipe Length(Actual)	$\leq 50\text{m}$ (28kBtu/h) $\leq 65\text{m}$ (36/42kBtu/h) $\leq 100\text{m}$ (48/56kBtu/h) $\leq 130\text{m}$ (60kBtu/h)	$L1+L2+L3+a+b+c+d+e+f+g+h+i$	
	Maximum Piping(L)	Actual Length	$\leq 35\text{m}$ (28kBtu/h) $\leq 45\text{m}$ (36/42kBtu/h) $\leq 60\text{m}$ (48/56/60kBtu/h)	$L1+\max(a,b,c,d,e,f)$ (the number of IDU less than 6)
		Equivalent Length	$\leq 40\text{m}$ (28kBtu/h) $\leq 50\text{m}$ (36/42kBtu/h) $\leq 70\text{m}$ (48/56/60kBtu/h)	$L1+L2+\max(a,b,c,d)$ or $L1+L3+\max(e,f,g,h,i)$ (the number of IDU more than 6)
	Pipe Length(from the nearest branch pipe equivalent length(m))	$\leq 20\text{m}$	a, b, c, d, e, f, g, h, i	
Drop Height	Indoor Unit-Outdoor Unit Drop Height(H)	Outdoor Unit up	_____	
		Outdoor Unit Down	_____	
	Indoor Unit to Indoor Unit Drop Height(H)	$\leq 10\text{m}$	_____	

- When the outdoor unit connects only one indoor unit

Table 4-4

MODEL (kBtu/h)	The max height drop(m)		The length of refrigerant pipe(m)	The number of bends
	When outdoor unit is top	When outdoor unit is bottom		
28	10	10	20	less than 10
36	20	20	40	
42	20	20	40	
48	30	20	60	
56	30	20	60	
60	30	20	60	



NOTE

When the total equivalent piping length of liquid + gas side is $\geq 90\text{m}$, it must increase the size of main gas pipe as Table 4-5.

4.2.3 Select refrigerant pipe

Main pipes diameters (L1)

Table 4-5

Total capacity of The outdoor units A (kBtu/h)	Main pipe size when the total equivalent piping length of liquid + gas side is $< 90\text{m}$		Main pipe size when the total equivalent piping length of liquid + gas side is $\geq 90\text{m}$	
	gas pipe (mm)	liquid pipe (mm)	gas pipe (mm)	liquid pipe (mm)
$A < 56$	$\Phi 15.9$	$\Phi 9.5$	$\Phi 19.1$	$\Phi 9.5$
$A \geq 56$	$\Phi 19.1$	$\Phi 9.5$	$\Phi 22.2$	$\Phi 9.5$

Flexible branch header selection

Table 4-6

Connectable IDUs number	Model
2	DBRD-02S
3	DBRD-03S
4	DBRD-04S
5	DBRD-05S
6	DBRD-05S
7	DBRD-02S+DBRD-03S+DBRD-04S
8	DBRD-02S+DBRD-04S+DBRD-04S
9	DBRD-02S+DBRD-03S+DBRD-05S



NOTE

- The selection of branch header depends on the quantity of branches it connects to.
- The straight distance between copper pipe turning and the contiguous branch pipe is at least 0.5 m.
- The straight distance between the contiguous branch pipes is at least 0.5 m.
- The straight distance which the branch pipes connected to the IDU is at least 0.5 m.

The main pipes diameters of indoor unit Table 4-7

Total capacity of the downstream indoor units A (kBtu/h)	Indoor unit main pipe size (mm)	
	Gas pipe	liquid pipe
$A < 52$	$\Phi 15.9$	$\Phi 9.5$
$A \geq 52$	$\Phi 19.1$	$\Phi 9.5$



NOTE

- Choose indoor unit main pipes from the above table in accordance with the total capacity of all the indoor units connected downstream. Do not let the indoor unit main pipe exceed the main pipe chosen by outdoor unit capacity.

The branch pipes diameters of indoor unit

Table 4-8

Refrigerant	Indoor Unit Capacity A (kBtu/h)	Gas pipe (Φ)	Liquid pipe (Φ)
R410A	$A \leq 15$	12.7	6.4
	$A \geq 19$	15.9	9.5

The pipe thickness of the refrigerant piping shall comply with the applicable legislation.

The minimal pipe thickness for R410A piping must be in accordance with the table below.

Table 4-9

Piping outer diameter (mm)	Minimum thickness (mm)	Temper grade
$\phi 6.4$	0.80	M-type
$\phi 9.5$	0.80	M-type
$\phi 12.7$	1.00	M-type
$\phi 15.9$	1.00	M-type
$\phi 19.1$	1.00	M-type
$\phi 22.2$	1.00	Y2-type



NOTE

- Material: Only seamless phosphorus-deoxidized copper piping that complies with all applicable legislation should be used.
- Thicknesses: Temper grades and minimum thicknesses for different diameters of piping should comply with local regulations.
- Design pressure of R410 refrigerant is 4.4MPa (44bar).

An example of refrigerant piping selection

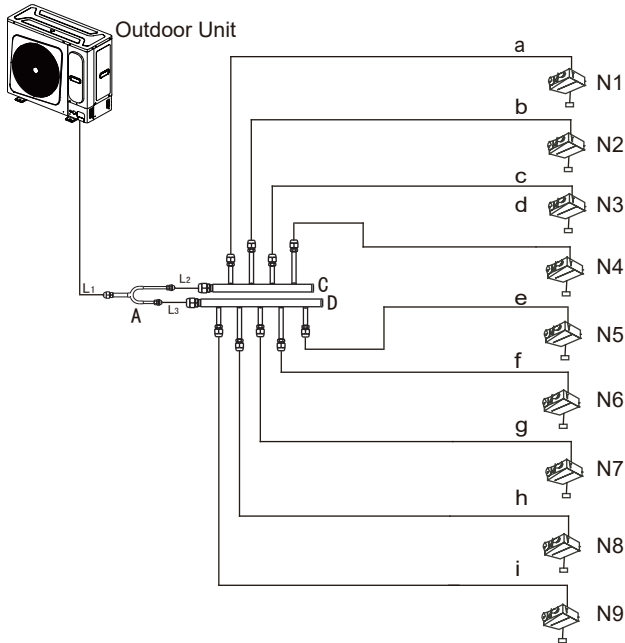

Fig.4-13

The example below illustrates the piping selection procedure for a system consisting of an outdoor unit (56 kBtu/h) and 9 indoor units (7 kBtu/h × 9), as shown in Figure 4-12. The system's total equivalent length of all liquid and gas pipes is not more than 90m.

- Select main pipe (L1)

The outdoor unit capacity is 56 kBtu/h, and the system's total equivalent length of all liquid and gas pipes is not more than 90m. So refer to Table 4-5, the main gas and liquid pipe size is $\Phi 19.1$ and $\Phi 9.5$ respectively.

- Select branch header (A, C, D)

9 indoor units are connected to the outdoor unit. According to Table 4-6, select DXFQT2-02, DXFQT4-02 and DXFQT5-02.

- Select indoor unit main pipe (L2, L3)

The downstream indoor units of L2 are N1 to N4, with the capacity of 28 kBtu/h. Refer to Table 4-7, the gas and liquid pipe size of L1 $\Phi 15.9$ and $\Phi 9.5$ respectively.

Similarly, the pipe size of L2 is $\Phi 15.9$ and $\Phi 9.5$.

- Select indoor unit branch pipe (a to i)

The capacity of each indoor unit is 7 kBtu/h. According to Table 4-8, Each indoor unit branch pipe size from a to i is $\Phi 12.7$ and $\Phi 6.4$.

5. OUTDOOR UNIT INSTALLATION

5.1 Prepare structure for installation

- Make concrete foundation according to the specifications of the outdoor units.(refer to Fig.5-1)
- Fasten the feet of this unit with bolts firmly to prevent it from collapsing in case of earthquake or strong wind. (refer to Fig.5-1)

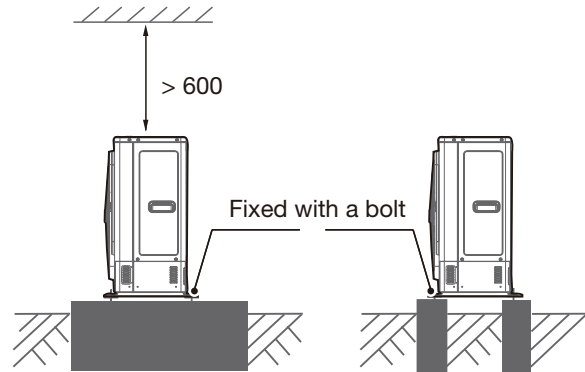

Fig.5-1

5.2 Remove dirt or water in the piping

Make sure there is no any dirt or water before connecting the piping to the outdoor units and indoor units.

Wash the piping with high pressure nitrogen, never use refrigerant of outdoor unit.

5.3 Refrigerant piping connection



CAUTION

- Please pay attention to avoid the components while connect to the connecting pipes.
- To prevent the refrigerant piping from oxidizing inside when welding, it is necessary to charge nitrogen, or oxide will chock the circulation system.

The indoor and outdoor connecting pipe interface and power line outlet

Various piping and wiring patterns can be selected,such as out from the front ,the back the side ,and undersurface, etc.

(The follow display the locations of several piping and wiring knock-off interfaces)

The connection method of flaring (28kBtu/h)

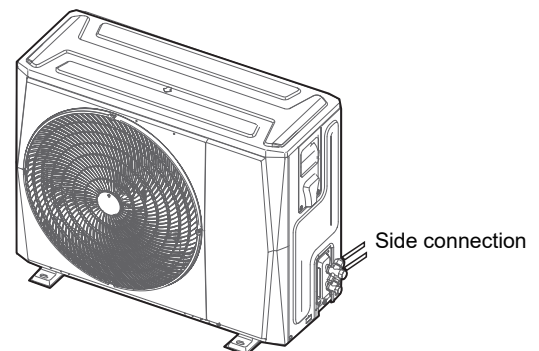

Fig.5-2

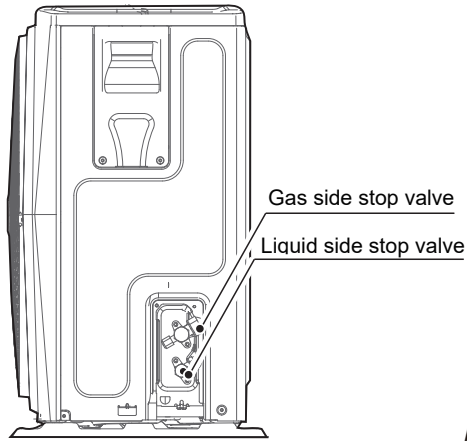

Fig.5-3

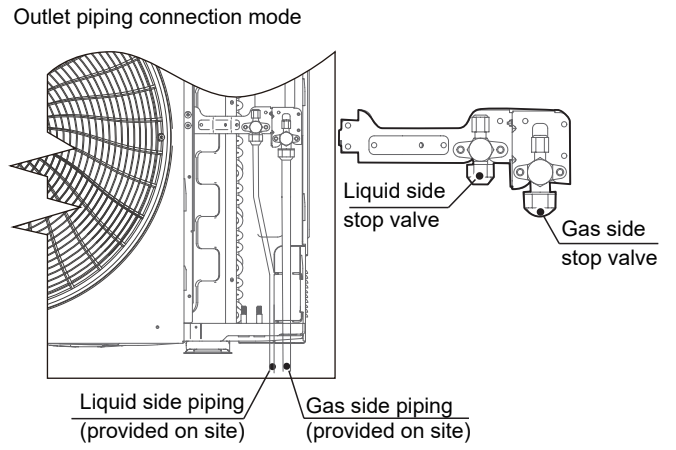

Fig.5-7

The connection method of flaring

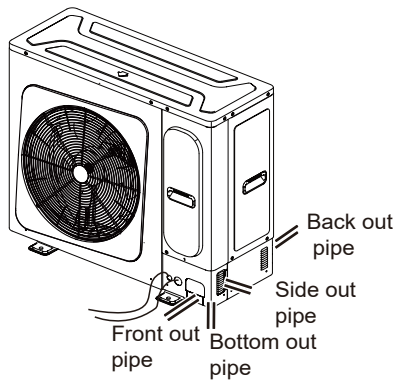

Fig.5-4

Back outlet piping connection mode

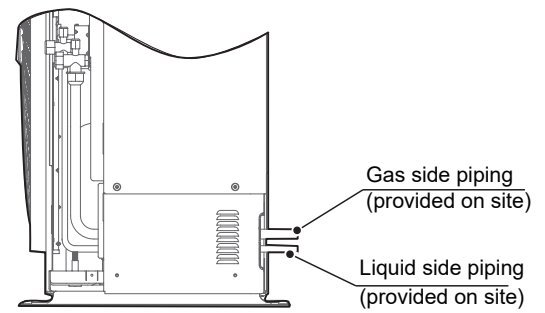

Fig.5-8

Forward piping connection mode (36/42/48/kBtu/h)

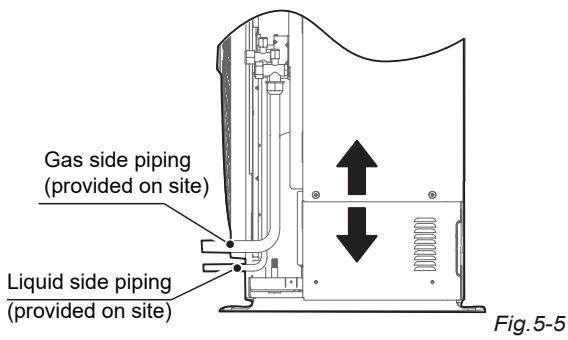

Fig.5-5

Forward piping connection mode (56/kBtu/h)

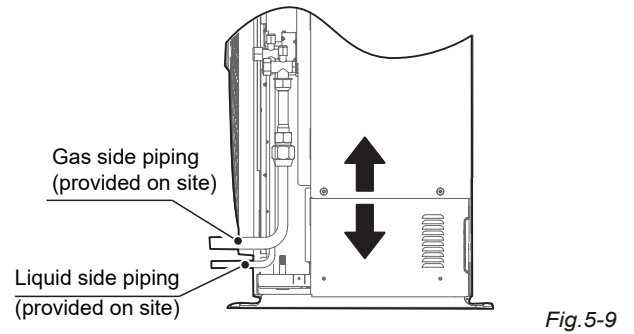

Fig.5-9

Side outlet connection mode

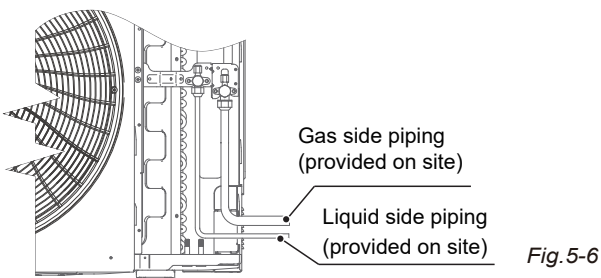

Fig.5-6

Side outlet connection mode

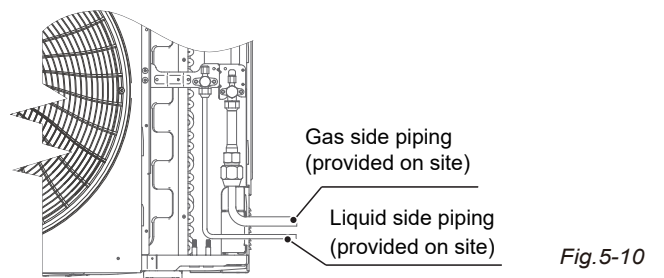

Fig.5-10

Outlet piping connection mode

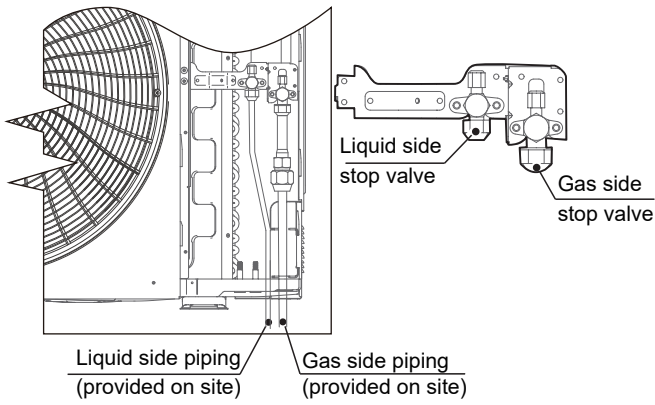

Fig. 5-11

Outlet piping connection mode

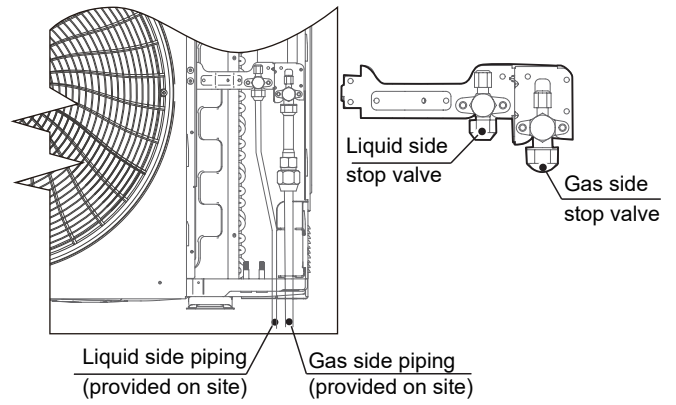

Fig. 5-15

Back outlet piping connection mode

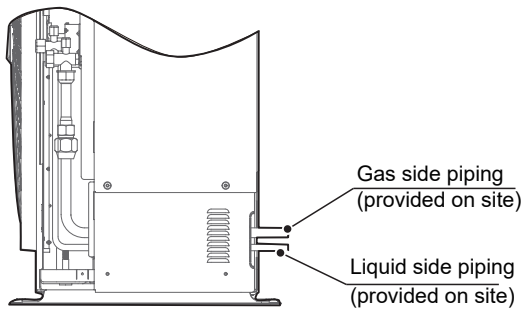

Fig. 5-12

Back outlet piping connection mode

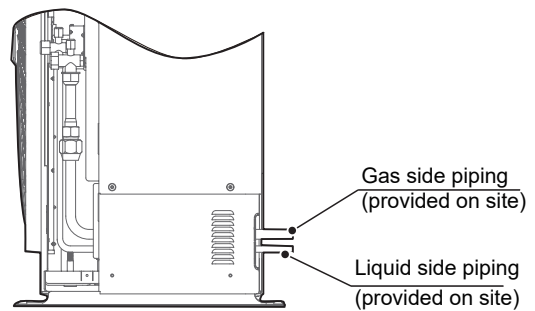

Fig. 5-16

Forward piping connection mode (60kBtu/h)

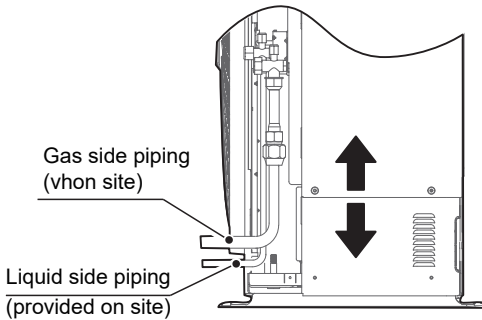

Fig. 5-13

Side outlet connection mode

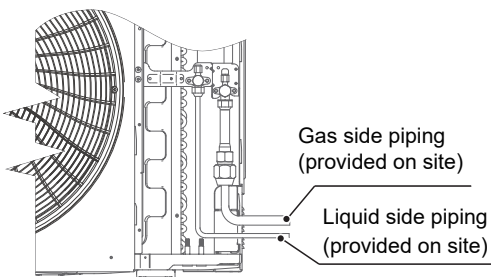

Fig. 5-14



CAUTION

- Side out pipe: please remove the L-shape metal plate, otherwise can not wiring.
- Back out pipe: please wipe off the piping support rubber blanket beside the inner outlet pipe cover of the machine while back side getting out pipes.
- Front out pipe: cut the frontal hole of the pipe-outlet plate. The method of the out pipe in the same way of the back out pipe.
- Undersurface outlet pipe: the knock out should from inside to outside, and then piping and wiring through this. Pay attention to the piping the fat connecting pipe should out from the largest hole, otherwise the pipes will be rubbed. Please do the moth proofing for the knocked out hole, to avoid the pest processing into and destroy the components.

5.4 Leak Detection

Use soapy water or a leak detector to check whether air leaks at each joint.

- A and B indicate check valves of ODU.
- C and D indicate IDU connecting pipe ports.
- All of the connection ports between branch header and refrigerant pipe.

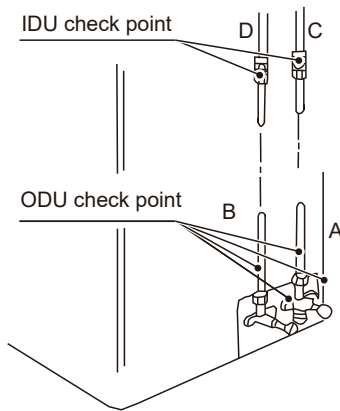

Fig. 5-17

5.5 Heat Insulation

Carry out heat insulation treatment for the pipes at the gas and liquid sides respectively. Pipes on the liquid and gas sides have a low temperature during cooling. Take sufficient insulation measures to prevent condensation (see the figure 5-18).

The gas pipe must be treated with the closed-cell foam insulation material, which reaches the non-flammable level of B1 and heat resistance of over 120 °C.

When the outer diameter of the copper pipe is not greater than $\Phi 12.7$ mm, the thickness of insulation layer should be greater than 15 mm.

When the outer diameter of copper pipe is equal to or greater than $\Phi 15.9$ mm, the thickness of insulation layer should be greater than 20 mm.

The attached insulation material for the part of the IDU where the pipe connects must undergo heat insulation treatment without gaps.

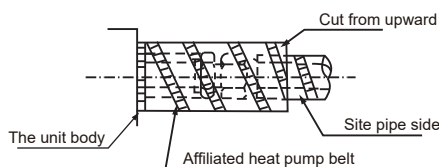

Fig. 5-18

5.6 Airtight Test

Air tightness test – nitrogen must be used.

Increase the pressure from the liquid pipe and gas pipe to 4.0 MPa at the same time (not exceeding 4.0 MPa). If the pressure does not drop in 24 hours, the test is passed.

When the pressure drops, check the leakage position .

And after you make sure that there is no leakage, discharge the nitrogen.



CAUTION

- Never use oxygen, combustible gas, or poisonous gas in the air tightness test.
- To prevent damage to the equipment, the pressure must not be held for too long.

5.7 Air Purge with Vacuum Pump

- Use a vacuum pump that can evacuate the pipe to the pressure of less than -100.7 kPa (5 Torr, -755 mmHg). When the pump is stopped, do not let the pump oil flow back into the refrigerant pipe.
- The liquid and gas pipes should be evacuated with a vacuum pump for more than two hours to the pressure of less than -100.7kPa.
- Then, place the pipes with the pressure of less than -100.7 kPa for more than one hour, and check whether the reading of the vacuum gauge rises. (If the reading rises, there is residual water or gas leakage in the system. The leakage must be checked and solved and the test should be performed again.)
- Water may enter into pipes in the following conditions: the installation is carried out in rainy seasons and the installation period is long; the pipes are condensed inside; rainwater enters the pipes.
- After the above vacuum drying of two hours, use nitrogen to increase the pressure to 0.05 MPa (vacuum breaking), and use a vacuum pump to decrease the pressure to lower than -100.7kPa or below and hold the pressure for one hour (vacuum drying).
- If the pressure cannot be decreased to lower than -100.7 kPa after two-hour vacuuming, repeat the vacuum breaking and vacuum process. After that, place the vacuum pipes for one hour, and then check whether the reading of the vacuum gauge rises.



CAUTION

- Use a vacuum pump to perform the vacuuming process. Do not use refrigerant gas to discharge air.
- Use a vacuum pump that can vacuumed the pipe to the pressure of less than -100.7 kPa (5 Torr, -755 mmHg). When the pump is stopped, do not let the pump oil flow back into the refrigerant pipe.
- In order to prevent the entry of impurities, the R410A special tool must be used to ensure the compression strength. Use a filing hose with a top rod to connect to the maintenance access of the check valve or the refrigerant filing port.

5.8 Refrigerant Amount to be Added

Calculate the amount of the R410A refrigerant to be added based on the diameter and length of the liquid pipes of the ODU and IDUs.

Table 5-1

Liquid Piping Diameter (mm OD)	Additional refrigerant charge per meter of equivalent length of liquid piping (kg)
Φ6.4	0.022
Φ9.5	0.054
Φ12.7	0.110
Φ15.9	0.170



NOTE

If "Arc" series indoor units are present in the system, the amount of additional refrigerant charged in the system should be decreased 100 gram for each LUNE series indoor unit present in the system.

Besides, calculate a certain equivalent pipe length of each branch header as Table 5-2.

Table 5-2

Code	Model	Refrigerant Amount to be Added
A	DBRD-02S	Equal to 0.5m length of liquid piping
B	DBRD-03S	Equal to 1m length of liquid piping
C	DBRD-04S	Equal to 1m length of liquid piping
D	DBRD-05S	Equal to 1m length of liquid piping
E	DBRD-06S	Equal to 1m length of liquid piping



NOTE

The diameter of liquid pipe shall be subject to the diameter of main pipe of branch joints. Refer to Section 4.2 for the diameter of main pipe

6. ELECTRICAL WIRING

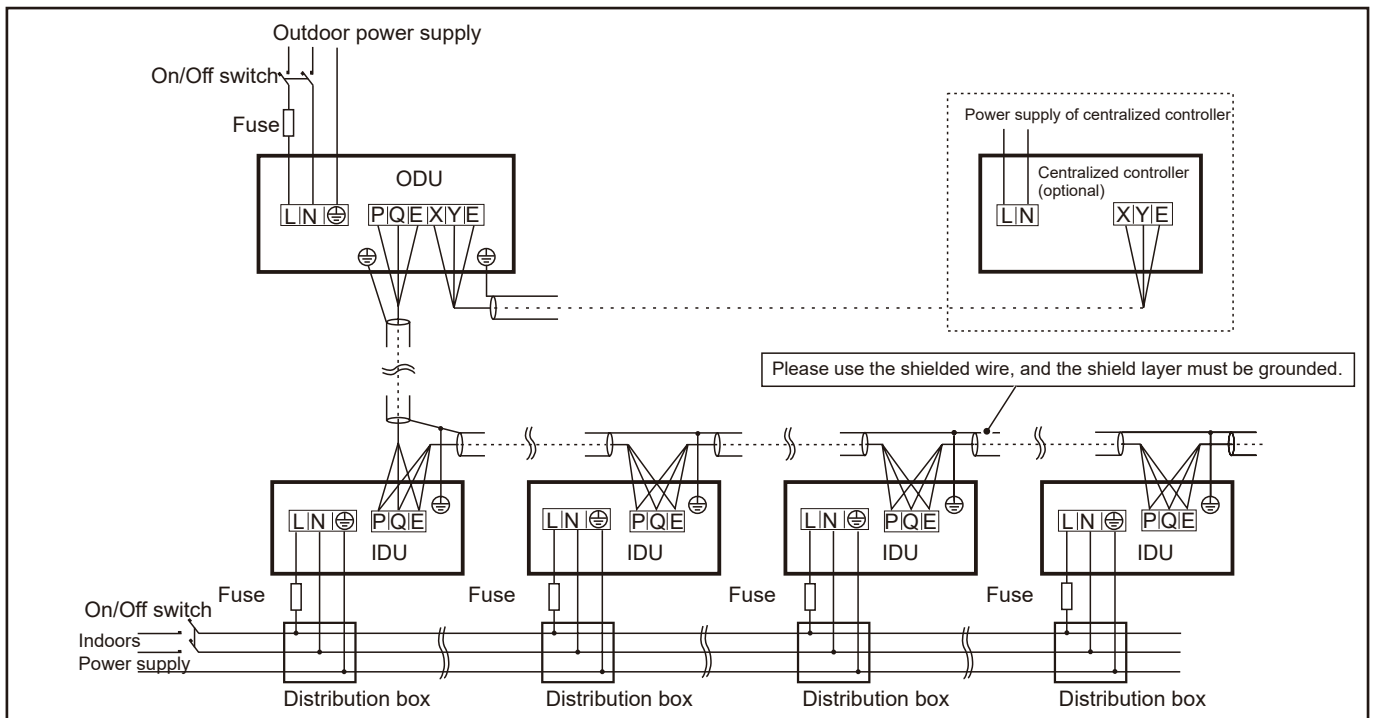

ODU electrical control system connection diagram

Fig. 6-1



CAUTION

- Please select power source for indoor unit and outdoor unit respectively.
- The power supply has specified branch circuit with leakage protector and manual switch.
- The outdoor unit model which corresponding to different outdoor unit power supply should refer to the nameplate.
(Please set all the indoor unit power of one system into the same branch circuit.)
- Please put the connective wire system between indoor unit and outdoor unit with the refrigerant system together.
- Use 3-core shielded wire as indoor unit and outdoor unit signal wire.
- The installation should comply with local electric standard.
- Power wiring should be engaged by specialized electrician.

6.1 Outdoor Unit Wiring

The Specification of Power

Table 6-1

Power Supply		220-240V~ 1Ph 50/60Hz					
Model	Capacity(kBtu/h)	28	36	42	48	56	60
Power Supply	Hz	50/60	50/60	50/60	50/60	50/60	50/60
	Voltage(V)	220-240	220-240	220-240	220-240	220-240	220-240
	Min.(V)	198	198	198	198	198	198
	Max.(V)	264	264	264	264	264	264
	MCA(A)	21.25	28.75	35	40	40	40
	TOCA(A)	18.1	24	29	33	33	33
Compressor	MFA(A)	25	32	40	40	40	40
	MSC	Soft start	Soft start	Soft start	Soft start	Soft start	Soft start
OFM	RLA(A)	9.45	9.45	12.3	15.5	15.5	15.5
	Power(kW)	0.08	0.17	0.17	0.17	0.17	0.17
OFM	FLA(A)	1.0	1.52	1.52	1.52	1.52	1.52



CAUTION

Equipment complying with IEC 61000-3-12.
A disconnection device having an air gap contact separation in all active conductors should be incorporated in the fixed wiring according to the National Wiring Regulation.



CAUTION

The reserved function is indicated in broken line table, users can select it when necessary.

Indoor/Outdoor Unit Signal Wire

Connect the wire according to their numbers.

Wrong connection may cause malfunction .

Wiring Connection

Seal the wiring connection with the insulation material , or the condensing dew will be caused.



NOTE

The air-conditioners can connect with Central Control Monitor (CCM). Before operation, please wiring correctly and set system address and network address of indoor units

■ Wiring Terminal Description

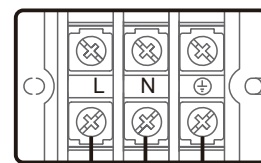

ODU power supply
220V~240V 50/60Hz

Fig. 6-2

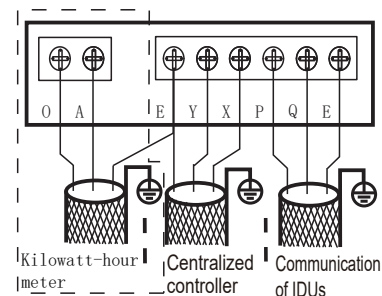

Fig. 6-3



CAUTION

Only the dedicated meter of manufacturer can be used on the unit.
For the wiring method of the meter, please consult the manufacturer's professional service personnel.
Reserved digital multimeter interface for 28~56kBtu/h.
The arrangement of OAE, XYE and PQE depends on the unit

Note: The wired controller and centralized controller in the dashed box are optional accessories. If necessary, please contact the local distributor for purchase.

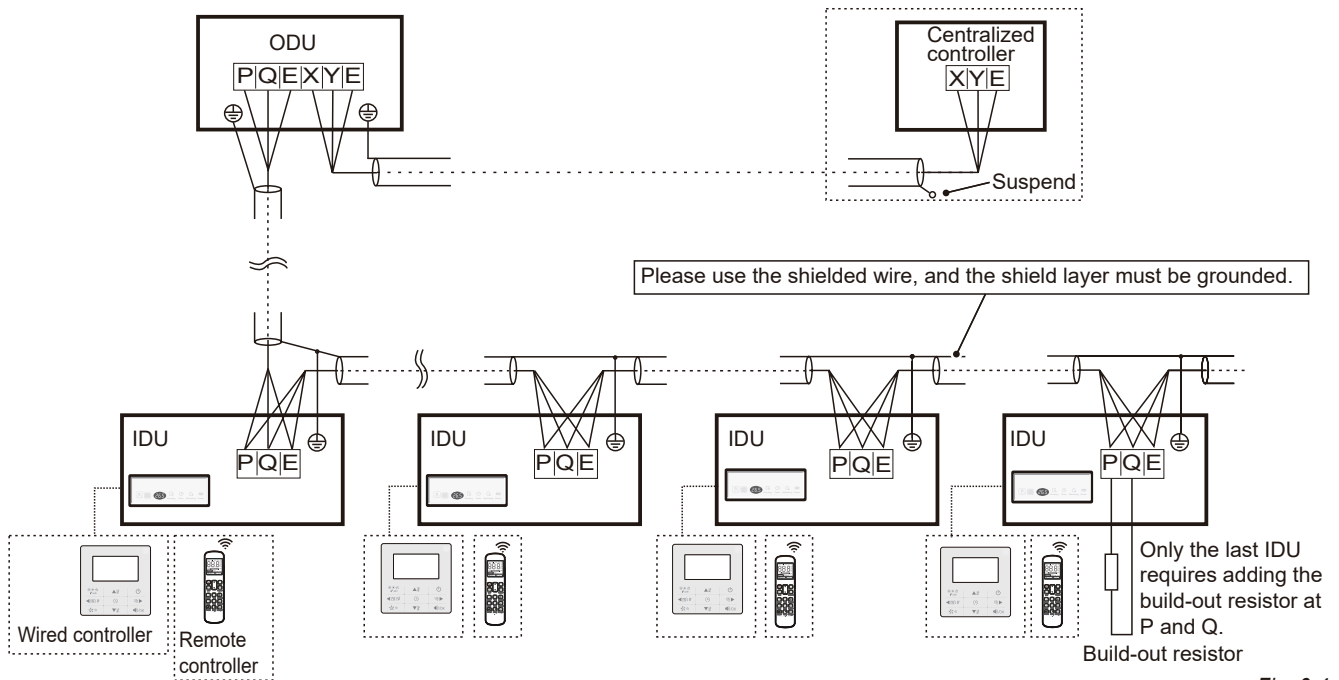

Fig. 6-4



CAUTION

- When the power cable is parallel to the signal wire, make sure that they are enclosed in respective conduits and are kept a reasonable wire spacing. (Distance between power cables: less than 10A-300mm; less than 50A-500mm)
- The three-core shielded cable is used as the signal cables of the IDUs and ODU, and the shield layer must be grounded as required.
- The display box and build-out resistor are IDU accessories. The remote controller, centralized controller and wired controller are optional accessories. If necessary, contact the local distributor for purchase. (Note: The BP3 series IDUs provide standard remote controllers.)

■ Safety device requirements

1. Select the wire diameters (minimum value) individually for each unit based on the table 6-1 and table 6-3, where the MCA in table 6-1 means Rated current in table 6-3. In case the MCA exceeds 40A, the wire diameters should be selected according to the table 6-3 is 6 to 16.
2. Maximum allowable voltage range variation between phases is 2%.
3. Select circuit breaker that having a contact separation in all poles not less than 3 mm providing full disconnection, where MFA is used to select the current circuit breakers and residual current operation breakers:

Table 6-3

Rated current of appliance(A)	Nominal cross-sectional area (mm ²)	
	Flexible cords	Cable for fixed wiring
≤3	0.5 and 0.75	1 to 2.5
>3 and ≤6	0.75 and 1	1 to 2.5
>6 and ≤10	1 and 1.5	1 to 2.5
>10 and ≤16	1.5 and 2.5	1.5 to 4
>16 and ≤25	2.5 and 4	2.5 to 6
>25 and ≤32	4 and 6	4 to 10
>32 and ≤50	6 and 10	6 to 16
>50 and ≤63	10 and 16	10 to 25

6.2 Indoor Unit Wiring

Power Supply Table 6-2

Capacity(kBtu/h)		7~56
Indoor Unit Power	Phase	1-Phase
	Voltage and Frequency	220-240V~ 50/60Hz
	Power Wiring Size	Refer to Table 6-3 for wire size
Circuit Breaker (A)		16
Indoor Unit /Outdoor Unit Signal Wire (mm ²) (Weak electric signal)		3-core shielded wire 3X0.75

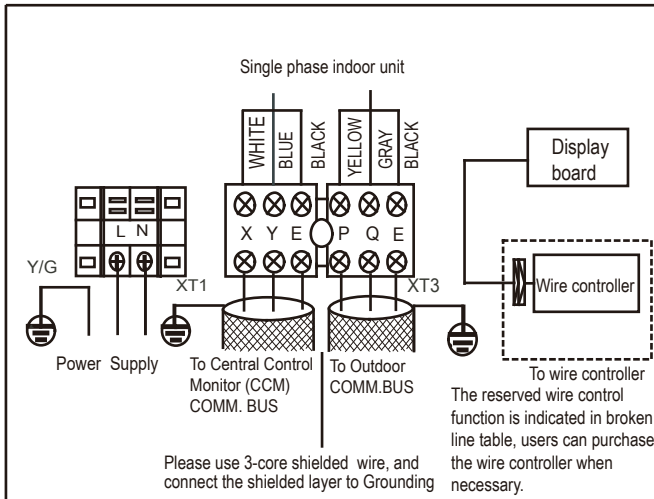

Fig. 6-5

1. Signal wire is 3-core, polarized wire. Use 3-core shield wire to prevent interference. The grounding method now is grounding the closed end of the shield wire and opening (insulating) at the end. Shield is to be grounded.
2. The control between outdoor unit and indoor unit is BUS type. Addresses is set on field during the installation.



CAUTION

Indoor/Outdoor unit signal wire is low voltage circuit. Do not let it touch the high voltage power wire and put it to gather with power cord in the same wire distribution pipe.



NOTE

The wire diameter and continuous length is under the condition that the voltage vibration is within 2%. If the continuous length is exceed showing value, choose the wire diameter follow relevant regulation.

Indoor unit power supply wiring

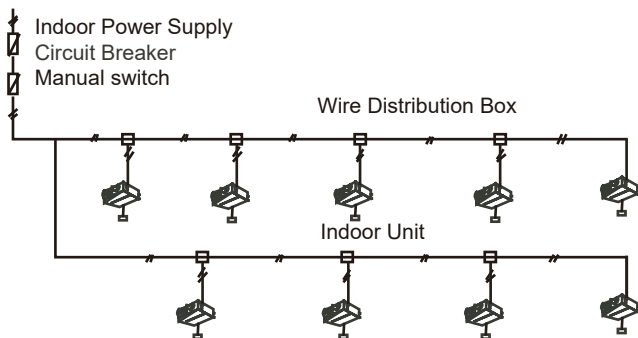

Fig. 6-6



CAUTION

1. Refrigerant piping system, indoor unit-indoor unit connection signal wires and indoor unit-outdoor unit connection signal wire are in the same system.
2. When power cord is parallel with signal wire, please put them into separate wire distribution pipes, and leave a proper distance. (Reference distance: It is 300mm when current capacity of power cord is less than 10A, or 500mm when 50A).

- Please use shield wire as indoor unit/outdoor unit signal wire.

Indoor/Outdoor unit signal wire wiring

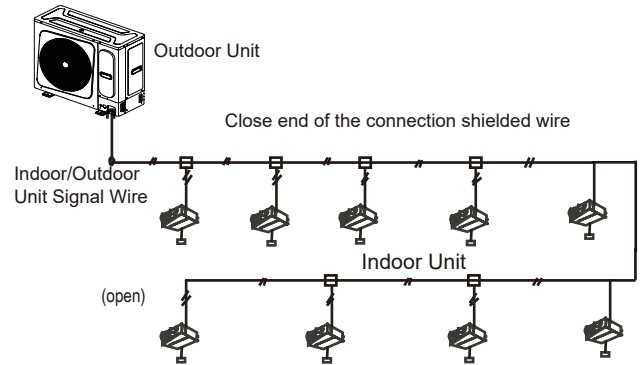

In broken line table, users can purchase the wire controller when necessary.

Fig. 6-7

7. CONFIGURATION

The ODU main control board contains two buttons, SW1 and SW2, as Fig. 7-1. SW1 is for test running while SW2 is for checking system parameters.

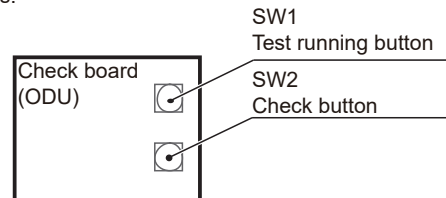

Fig. 7-1

Test running control

The ODU main control board is provided with a test running button SW1. The button is pressed once to send a test running signal to all IDUs at once, forcing all IDUs to start cooling operation. The outdoor compressor runs at a fixed frequency according to the table and the IDU fan operates at a high speed. Press the button again to exit the test running operation.

Test running frequency table

Model	28/36/42/48/56/60kBtu/h single phase
Test running frequency (Hz)	44



CAUTION

Operate the switches and push buttons with an insulate stick (such as a closed ball-point pen) or insulating gloves to avoid touching of live parts.

Display function

The ODU main control board is equipped with the check button (SW2 for 28/36/42/48/56 kBtu/h). The digital tubes on the main control board will show the parameters of the air conditioner in the following order (the button displays one parameter at a time).

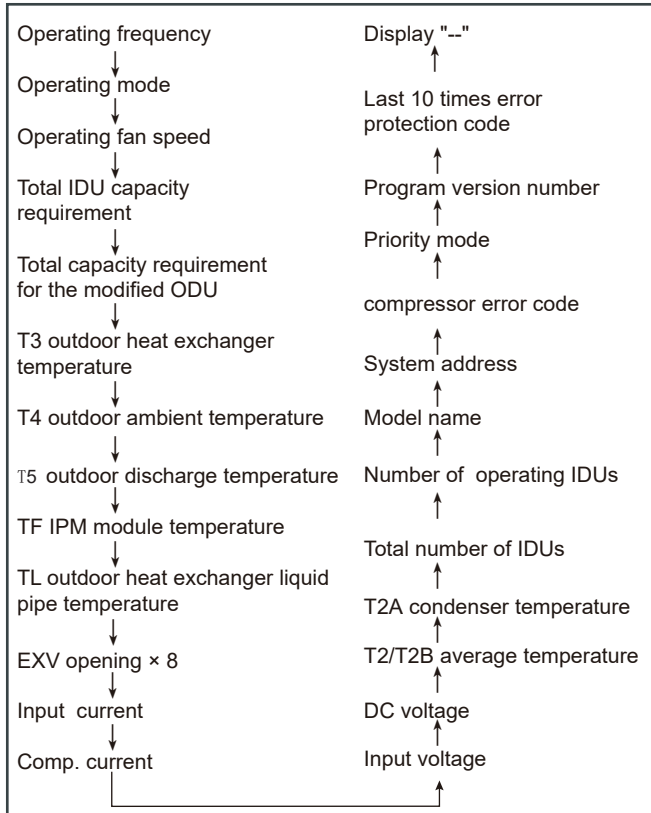

NOTE:

- T2: Indoor heat exchanger pipe temperature.
- T2A: Indoor heat exchanger inlet temperature.
- T2B: Indoor heat exchanger outlet temperature.
- T3: Outdoor heat exchanger temperature.
- T4: Outdoor ambient temperature.
- T5: Discharge temperature.
- TF: IPM module temperature.
- TL: Outdoor heat exchanger liquid pipe temperature.
- EXV: Electronic expansion value



NOTE

- 12 hours preheating is imperative after turn on the power switch. Please do not shut down the power when the unit is supposed to stop running in 24h or shorter time. (This is to warm the crankcase heat box to avoid compulsive start of compressor.)
- Pay attention not to block the air inlet and outlet. Blocks may decrease the efficiency of the unit or startup the protector, which will stop running.
- Operate the switches and push buttons with an insulated stick (such as a closed ball-point pen) to avoid touching of live parts.

8. TEST RUNNING

Operate according to "gist for test running" on the electric control box cover.



CAUTION

- Test running can not start until the outdoor unit has been connected to the power for 12hr.
- Test running can not start until all the valves are affirmed open.
- Never make the forced running. (Or the protector sits back, danger will occur.)

9. PRECAUTIONS ON REFRIGERANT LEAKAGE

This air conditioner (A/C) adopts innocuous and nonflammable refrigerant. The locating room of the A/C should be big enough that any refrigerant leakage is unable to reach critical thickness. So certain essential action can be taken on time.

- Critical thickness-----the Max. thickness of Freon without any harm to person.
- Refrigerant critical thickness: 0.44[kg/m³] for R410A.

Confirm the critical thickness through follow steps, and take necessary actions.

1. Calculate the sum of the charge amount (A[kg]) Total Refrigerant amount = factory refrigerant amount + additional refrigerant charge amount
2. Calculate the indoor cubage (B[m³]) (as the minimum cubage).
3. Calculate the refrigerant thickness

$$\frac{A[\text{kg}]}{B[\text{m}^3]} \leq \text{critical thickness}$$

Counter measure against over high thickness

1. Install mechanical ventilator to reduce the refrigerant thickness under critical level. (ventilate regularly)
2. Install leak alarm facility related to mechanical ventilator if you can not regularly ventilate.

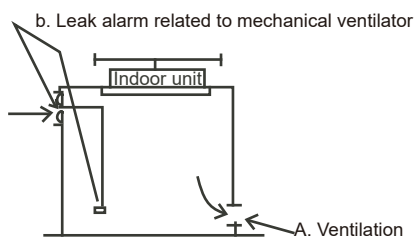
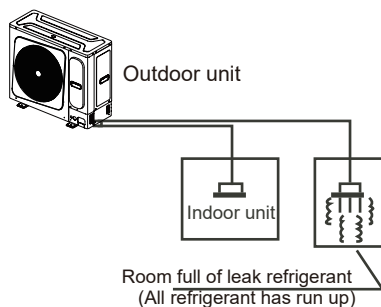

(Leak hunting siren should be installed in places easily keep refrigerant)

Fig. 9-1

9.1 Important information for the used refrigerant

This product has the fluorinated gas, it is forbidden to release to air. Refrigerant type: R410A; Value of GWP: 2088; GWP=Global Warming Potential

Table 9-1

Model	Factory charge	
	Refrigerant/kg	tons CO ₂ equivalent
28kBTu/h	1.70	3.55
36kBTu/h	2.30	4.80
42kBTu/h	2.40	5.01
48kBTu/h	3.10	6.47
56kBTu/h	3.60	7.52
60kBTu/h	4.60	9.60

Attention:

Frequency of Refrigerant Leak Checks

1) For equipment that contains fluorinated greenhouse gases in quantities of 5 tons of CO₂ equivalent or more, but of less than 50 tonnes of CO₂ equipment, at least every 12 months, or where a leakage detection system is installed, at least every 24 months.

2) For equipment that contains fluorinated greenhouse gases in quantities of 50 tons of CO₂ equivalent or more, but of less than 500 tons of CO₂ equipment, at least every six months, or where a leakage detection system is installed, at least every 12 months.

3) For equipment that contains fluorinated greenhouse gases in quantities of 500 tons of CO₂ equivalent or more, at least every three months, or where a leakage detection system is installed, at least every six months.

4) Non-hermetically sealed equipment charged with fluorinated greenhouse gases shall only be sold to the end user where evidence is providing that the installation is to be carried out by an undertaking certified person.

5) Only certificated person is allowed to do installation, operation and maintenance.

10. TURN OVER TO CUSTOMER

The operation manual of indoor unit and operation manual of outdoor unit must be turned over to the customer. Explain the contents in the operation manual to the customers in details.



Importado por: **INTENSITY AIR, S. A. DE C. V.**
RFC: IAI-100609-SRA.
Río Amacuzac #1125, Col. Valle Ote., CP. 66269
San Pedro Garza García, Nuevo León, México

Note: Product specifications change from time to time as product improvements and developments are released and may vary from those in this document.