



INTENSITY[®]
AIR CONDITIONING



HORIZONTAL & VERTICAL AIR HANDLING UNIT

IAHWH06KF-5/6, IAHWH08KF-5/6, IAHWH12KF-5/6, IAHWH14KF-5/6,
IAHWH16KF-5/6, IAHWH24KF-5/6, IAHWH28KF-5/6, IAHWH34KF-5/6,
IAHWV16KF-5/6, IAHWV24KF-5/6, IAHWV28KF-5/6, IAHWV34KF-5/6.

INSTALLATION OPERATION AND MAINTENANCE MANUAL

Thank you very much for purchasing our air conditioner,
Before using your air conditioner, please read this manual carefully and keep it for future reference.



PRODUCT INTRODUCTION.....	1
INSTALLATION.....	3
UNIT RUNNING AND OPERATION.....	5
UNIT MAINTENANCE.....	6
COMMON FAULTS ANALYSIS, AND ELIMINATION.....	8
TYPICAL INSTALLATION DRAWING.....	9

1. PRODUCT INTRODUCTION

1.1 Brief Introduction

The IAHHW /V Series Air Handling Unit is a central air-conditioning terminal equipment, which uses the cooling/hot water as its cooling/heating source respectively. By structure, it integrates coil, fan, drain pan as a unit, producing cold/hot air; by panel structure, by the unit form, it divides into the horizontal-type unit, suspended and the vertical-type unit.

Air handling unit carries on the design and the manufacturing basing on the full absorption of the most recent development technology of the refrigeration air conditioning field, applies the high quality spare parts, also carries on the reasonable combination, thus causes the unit's running to be more effective and stable. The latest designs of the air handling unit range of air volume is 2000-40000 m³/h, total 33 models for the user's choice, and it's widely used in many fields, such as factory, supermarket, restaurant, chain store, entertainment place. Comparing to the general air conditioning equipments, the air handling unit has a higher performance-price ratio, lower running cost, creates a more comfortable environment for you.

1.2 Nomenclature

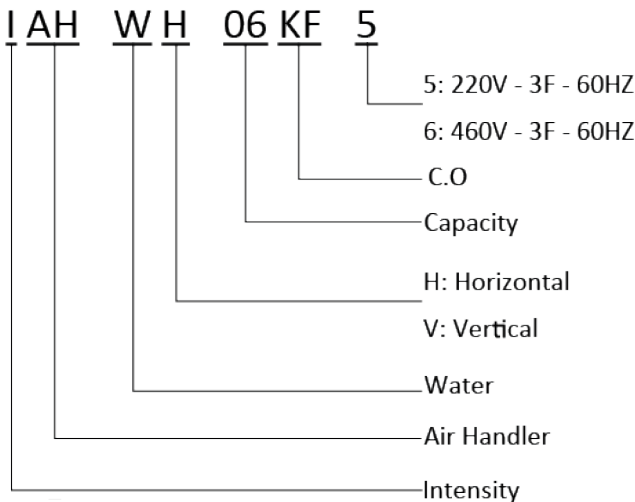

1.3 Models Schedule

1) Suspended Unit

Table 1-1

Table 1-1

220V	Model	IAHHW-06KF-5	IAHHW-08KF-5	IAHHW-12KF-5	IAHHW-14KF-5
	CFM	2000	3000	4000	5000
460V	Model	IAHHW-06KF-6	IAHHW-08KF-6	IAHHW-12KF-6	IAHHW-14KF-6
	CFM	2000	3000	4000	5000
220V	Model	IAHHW-16KF-5	IAHHW-24KF-5	IAHHW-28KF-5	IAHHW-34KF-5
	CFM	6000	8000	8800	8800
460V	Model	IAHHW-16KF-6	IAHHW-24KF-6	IAHHW-28KF-6	IAHHW-34KF-6
	CFM	6000	8000	8800	8800

2) Vertical Unit

Table 1-2

220V	Model	IAHWV-16KF-5	IAHWV-24KF-5	IAHWV-28KF-5	IAHWV-34KF-5
	CFM	6000	8000	10000	12000
460V	Model	IAHWV-16KF-6	IAHWV-24KF-6	IAHWV-28KF-6	IAHWV-34KF-6
	CFM	6000	8000	10000	12000



NOTE

Please refer to stylebook for more detail data.

The model does not include rows and pipe connection.

1.4 Product Features

■ Box body

- Using three dimensional compound aluminum alloy frame construction, coordinating with the compound double-decked with-filling heat preservation kneading board, makes the cabinet of the latest generation unit to be a true design of cooling bridge insulation. It avoids the energy loss because of cooling bridge and the leakage, there is no condensate water can shape on the unit outer panel, and no air permeating into the system without handling.

- The design of the inside unit is smooth and the interior is facilitated to be cleaned, which reduces the air perturbation and the kinetic energy loses, and effectively suppresses the accumulation of dust and the growth of bacterium. The internal function section is isolated by the back plate, and ceases the section short-circuits of the air.
- The flexible outline design and manufacturing, is convenient for the customer to carry on individuality ordering and the most effective utility of the building space.

- The convenient access door and the detachable panel enables an open overhauling space of the equipment interior component.

■ **Frame**

- The unit frame adopts the assembling type structure, consisted by the three dimensional compound mode of the chilled bridge aluminum alloy molding.
- The aluminum alloy molding uses the high quality T5 aluminum alloy to mold and then squeeze out to make, the surface have passed through the hardened grinding processing, thus having the outstanding mechanical strength, accurate size, artistic contour; the anodizing protective film of the aluminum surface, make its appearance looks better and more anti-corrosive.
- The space between the inside and outside aluminum alloy molding is filled with the special PVC foam plastics molding to separate the chilled bridge, and the inside is filled with the directly froth flinty high density polyurethane thermal insulation material, further strengthening the heat insulation performance and mechanical strength.
- Connection of the frame angle uses the strengthening plastic casting, assembles the overall frame with the aluminum alloy molding, the mechanical strength conforms to the CEN2 level standard (under the design operating mode, the distortion is smaller than 4mm/m).
- The design of entire unit frame is flexible, overhauling, disassembling and assembling is extremely convenient, especially for the large-scale and ultra-large type unit structure, is easy to carry on the scene assembly.
- Regarding to the partition supply of the air conditioning unit, we provide the special-purpose seal filler and joint, makes the scene connection fast and dense.

■ **Panel**

- The new plus thick panel of compound mode double-decked with-filling heat preservation, which is frothed to shape by the color steel plate; the galvanized sheet and the flinty polyurethane thermal insulation material, the frame uses the PVC flange strip to separate the chilled bridge between the double plate and the aluminum frame. In various aspects of heat preservation, sound insulation, fire protection, intensity, service life as well as the purity and so on, all have the optimum performance.
- Panel heat transfer coefficient $K \leq 0.03 \text{ W/m}^2 \cdot \text{K}$.

■ **Base**

- The base is shaped by the galvanizes steel plate's kneeing bend forming or the whole welding forming, connects the box body with bolt fastening.
- The height of base is 40 or 80 mm, may customize the base height according to the hydraulic packing height and project actual altitude.

■ **Filter**

- The unit equips with the plated primary filter as its standard filter, temporarily stop efficiency $\geq 65\%$. It has the features of firm structure, long service life, repeatedly clean and so on.
- All filters are installed on the galvanized sheet runner, the bilateral side are installed with the access door which is easy to open, which is advantageous for daily inspection, replacement and disassembly.

■ **Fan**

- The Fan is a forward or backward curved centrifugal type with double air supply. After some strict examinations of static balance, transient equilibrium and overall transient equilibrium, the balance precision is not lower than the ISO1940-G4.0 standard. Structure, stable performance.
- The specialized CAD shaping software is used on the optimized design, which gains the best operating point, efficiency and noise level.
- There are some series of products of multitudinous specification to be selected, can widely satisfy different situation and wide range of air volume and wind pressure's request.

■ **Motor**

- The motor is three-phase asynchronous machine, which is air-cooled and entire closed, has a higher reliability and longer service life.
- Type of saving energy: The motor has an optimized design, could obtain a higher efficiency, cause the obvious saving energy results.

■ **System of reducing vibration**

- Independently suspensive floating fluctuated system makes the fan and the motor move more tranquil, reduces the noise and energy consumption caused by the aerodynamic disturbance.

■ **Drain pan**

- The bottom drain pan employs the alternate level steep dry type antibacterial structure, can effectively suppress the sewage to be detained and the bacterium growth.
- Drain pan freeing port provides directly connection of the external thread, the outside packing water seal (selectable) is possible to guarantee draining water smooth, and not overflowing. All drain pan are tested by the experiment of water-testing and leakage-testing.

2. INSTALLATION

2.1 Transportation, Acceptance, Load And Onload

1) Transportation

- IAHWH/V series air handling unit sale to overseas are integral transported.

2) Inspection and acceptance

- Do check your unit item by item according to logistics list before acceptance. Please notify the dealer immediately when you find damages or losses .

- Files with the unit include the IOMM.

3) load and unload, carry and storage

- It's strongly recommended to load and unload the unit by forklift truck in site. Suspended and horizontal unit are equipped with wood base which include forklift truck hole (height: 60mm), and there also equipped with holes on steel base for vertical unit.
- Unit must be carried by crane or roller rather than crude drag to avoid damages, and the stow-wood should not be throw off till installation.
- Unit must be stored far away from dirtiness, rain, snow and animals to avoid damage. Do not damage the protect film. Unit should be laid away from sunbeam to avoid distortion. It's also indispensable to setup shed to avoid rain and snow, and the space between the shed and the unit should not lower than 2m for facility of pipe installation.

2.2 Unit Installation

1) Suspended Unit

There are four holes equipped on the suspended unit base. Four suspenders hang the unit indoor through nuts and shock absorbers. Do adjust tightness of the Blinding mechanism to ensure no vibration , no abnormal noise .The unit should be adjusted horizontal to enable better drainage of condensation water without damaging dynamic balance of fan which can extend unit life.

2) Horizontal, Vertical Unit

Horizontal and vertical unit is installed on the ground. Unit foundation should be concrete or metal platform and it's dimensions should meet unit length add 100mm, width add 100mm and height add 100-200mm. drain and floor drain should be equipped around the unit, and the error of unit platform diagonal can not exceed 5mm to ensure unit horizontally installed.

Horizontal/Vertical Unit

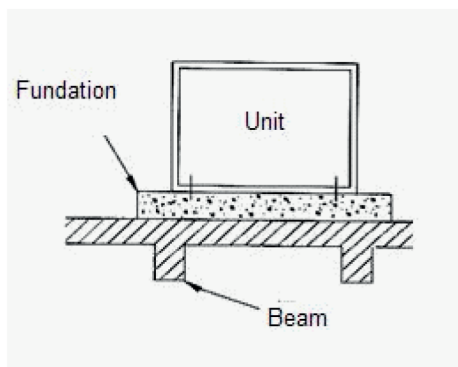

Fig 2-1

Suspended Unit

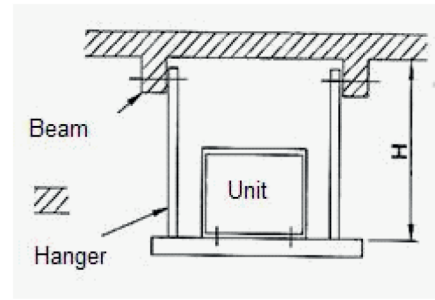

Fig 2-2

3) Units Installation Notes

- Suspended AHU suspender should have enough intensity and fixed point should be fast.
- Suspender length(H) should better be short.
- External shock absorber should adopt compression type, and it's structure as following drawing:

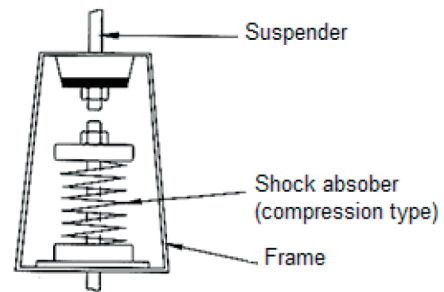

Fig 2-3

- Screw cap must be fastened without looseness when unit adopt screw connection. Top screw cap should be welded to avoid danger due to unit falling. Please refer follow drawing for details:

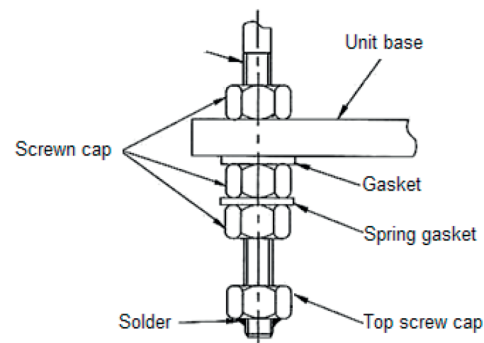

Fig 2-4

- Screw part of suspender should long enough to adjust levelness of suspended unit which can avoid water accumulation in drain pan due to deflection installation of unit.
- Unit should install near the beam, installation between beam will lack point of strenght and result in damage due to abnormal vibration. Unit should avoid install in some location such as meeting room, guest room and other location on high requirements on noise level.

2.3 Space Reservations of Unit

- Considering needs of unit maintenance, unit access door side should leave at least equal length of unit for disassembly components such as cooling coil, fan, motor, filters.
- Air inlet side should leave at least 800mm to ensure inlet air smoothness, thus unit heat exchanger can be adequately utilized and abnormal noise will be avoided.
- Enough space should be leaved under suspended unit to ensure condensated water pipe installation. (detail dimension refer to follow water pipe installation)

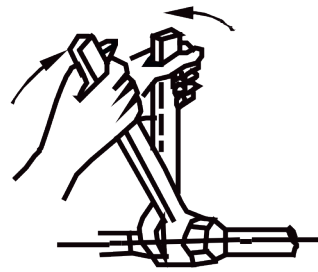

Fig 2-5

2.4 Air Pipe Installation And Connection

- Please select the appropriate air pipe according to unit air flow and static pressure. All air pipe thermal insulation should be handled, With anti-moisture layer of thermal insulation material to prevent absorption of water vapor.



NOTE

outlet pipe from the unit outlet to connect curved pipe, should be keep at least twice the size of a straight long side outlet pipe, otherwise it will result in additional loss of air pressure.

- Air inlet and outlet pipe should be installed the air volume control valve in order to facilitate system commissioning and make the air flow, air pressure appropriate. The joint between air inlet/outlet and air duct should be soft material.
- Air duct size should be designed according to «GB140-59 Ruled code for transportation pipe of liquid and gas», «GBJ19-87 heating, ventilation and air conditioning design criteria», Wind speed must be controlled to avoid high noise.
- Units should not bear the weight of external piping, all inlet / outlet air pipe should be bearing and fixed.
- Unit maintenance space required must be considered when installing piping.

2.5 Water Pipe Installation And Connection

- Inlet / outlet water pipe of cooling coil adopt screwed pipe joint, the screwed pipe joint should be wound with rubber belt, Pipe connection form is “down in up out”.

It's recommended to adopt soft joint for external inlet / outlet water pipe do use double monkey wrench and keep balance force when connect pipe as right drawing.

Units Inlet/outlet water pipe shall be installed regulating valve

- (except condensate drains), which is used to regulate water flow and cut off water source when maintenance. Units Inlet/outlet water pipe insulation measures should be adopted. Each Condensate drain must be installed U-shaped water seal, refer to the draw for the U-shaped water seal installation diagram.

2.6 Electrical Installations

- All requirements of components such as wiring cable, terminal must accord with Unit nameplate parameter requirements. There are some critical parameters such as: motor power, current, air flow rate, air Pressure, water temp., water flow rate and so on. The selection of transformer, no fuse breaker, wiring cable should base on motor current, and more than 10% capacity must be leaved as safety capacity.
- Connect power wire according to electrical diagram and ensure all nut is fastened. Power voltage and frequency must accord with unit requirements. voltage fluctuate value must less than 5%, frequency fluctuate value less than 2% when Unit running.
- Wiring should have good insulation and protect equipment, and insulation resistance should be more than 10MΩ when electrical components bearing 500V. Unit shell should have reliable earthing protect equipment.
- Check whether three phase (U,V,W) and PE terminal is firmly connected and whether power phase sequence accord with unit requirement before unit is electrified.

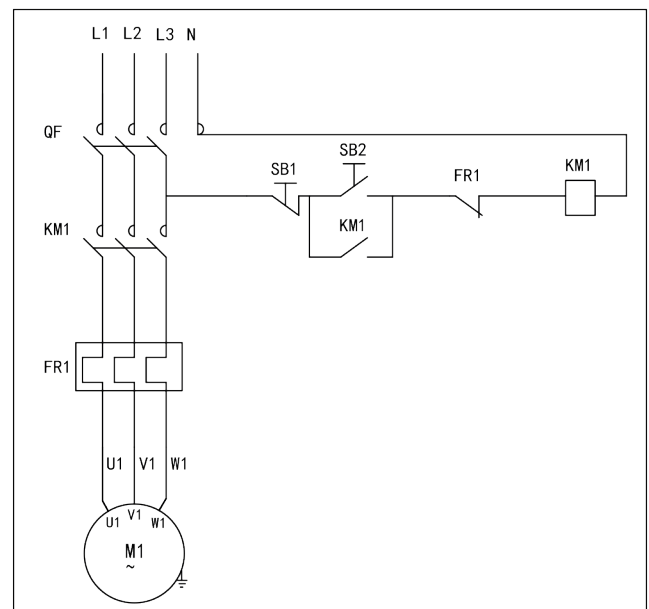

direct starting

Fig 2-6

3. UNIT RUNNING AND OPERATION

3.1 Unit Installation Inspection

- Clean inside and outside of unit to ensure no dust accumulated.
- Check whether there are loose components such as unit frame, panel and fan due to improper transportation and installation.
- Check whether gas tightness of inlet/outlet duct and maintenance door is up to the standard, check whether primary filter is properly installed.
- Clean condensing water U-shaped bend and add some water, check whether connecting pipe is correctly installed and whether water flow rate is up to the standard.

3.2 Electrical Inspection

- It's strongly recommended that voltage fluctuate value can not exceed $\pm 5\%$ and frequency fluctuate value can not exceed $\pm 2\%$.
- Check whether electrical wiring accord with electrical wiring diagram and Local electrical installation criterion.
- Check all electrical equipment connected with motor, light and control equipment and check whether wiring is correct, whether power accord with nameplate requirements, whether short circuit, overload and phase loss protect equipment is installed in power inlet side. All earth ling equipment must be properly installed.

3.3 Inspection of Fan and Fan Motor

- Check whether there is sundries in fan whorl, whether there is collision and friction between whorl and impeller when rotate impeller by hand and listen if there is abnormal noise on fan bearing.
- Inspect if fan, motor and pulley is loose. Check if tension of the belt can satisfy the requirement according to the figure shown below. (E.g. the 4 points shown in the figure) Check if the two pulleys are on the same plane. Check if fan, motor can rotate flexibly.

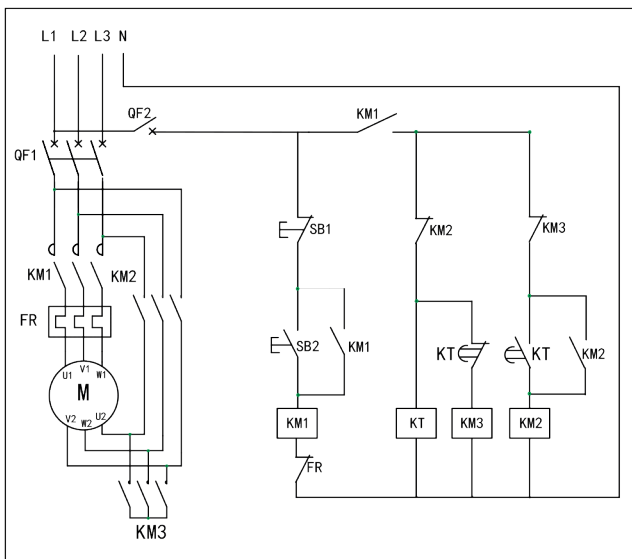

Y- Δ start (step start)

Fig 2-7

2.7 Condensated Water Drainage

The condensing water should be drained smoothly, otherwise the drain pan will be overflowed, consequently it will cause dripping or even some water will be brought out along with air. The connection between water seal (Manufacturers do not provide) and condensing water drainage pipe is shown as follow:

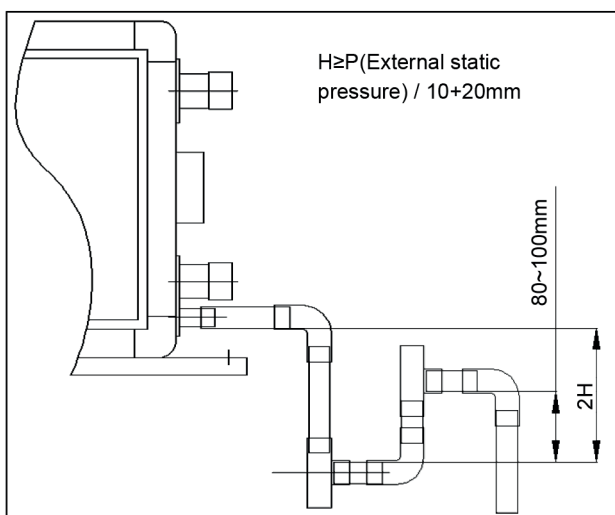

Condensing water drainage diagram

Fig 2-8

4 UNIT MAINTENANCE

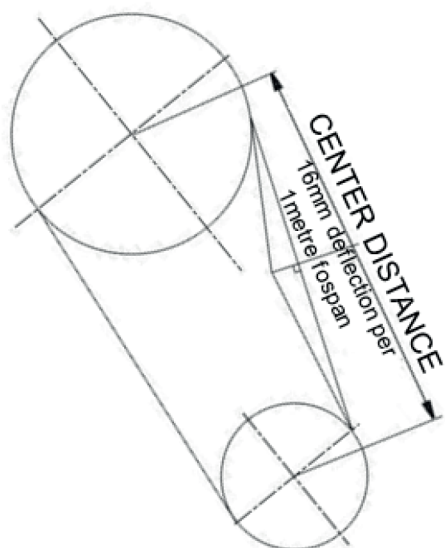

Schematic diagram of belt tension adjustment

Fig 3-1

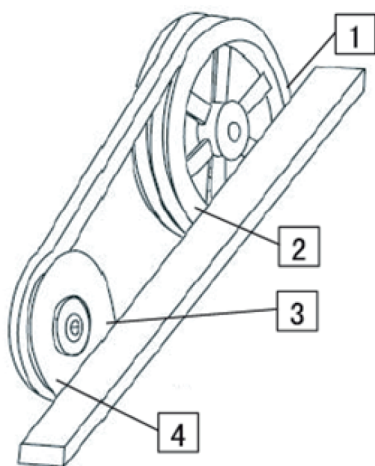

Use a straight ruler against the side of two pulleys

Schematic diagram of pulleys adjustment

Fig 3-2

- When the unit is running, check tension of the belt in a regular time. Do the inspection job according to requirements in 3-3
 - 1) Tension adjustment of the belt: If the belt tension is proper, it will help to avoid fan vibration, reduce noise and belt abrasion. Customers should check belt tension every week and do adjustment according to the following procedures if necessary: Loosen the 4 fixed bolts of motor. Tighten or loosen the bolts to move the motor.
 - a) Act in the middle of the belt perpendicularly with a finger. Adjust belt tension until there's deflection distance, please refer to Fig 3-1. If possible, it is better to use a tension frequency test device, in order to get a more precise tension.
 - c) Tighten the fixed bolt of motor again.
 - 2) Pulley revise: Fan pulley and motor pulley should on the same plane, or it will consume much more energy and curtail service life of belt. Every time after belt adjustment, you should check if positions of the 2 pulleys are correct, refer to figure 3-2, you can put a ruler on the same side of 2 pulleys to check if positions of 2 pulleys are correct. Check if point 1, point 2, point 3 and point 4 are in the same plane. If not, you can loosen fixed screws of fan pulleys and along the fan axle to slide fan pulleys. Loosen motor to adjust the angle on the fan slide way. Adjust to straightness $\leq 2\text{mm}$.

- The fan Bearing should be inspected once for a month, as follows:

After the unit start to run within 15 minutes, check whether the bearing is operating normally, if the grease is white, then open the bearing, remove the old grease, and clean the bearing using gasoline and dry the bearing. Then add new grease (the bearing lubricant 's main raw material is lithium), to the bearing shell 1/3. The bearing temperature rise is less than 40°C in operation which is appropriate, if the bearing is rusty result from the factors such as condensed water, then the bearing should be replaced immediately.
- When the unit is not running and heating system is not run-time in the winter, the water must be drained out the coil (system) or add the appropriate concentration antifreeze, otherwise the coil will be frost crack. (as follows: Fig 4-1)

- The unit should better be used under the relative humidity of 80%, when the humidity is higher, please install dehumidification equipment.
- The hot and cold water of the system should be soft water, at the same time, the coil should be cleaned regularly to prevent scale or other debris to plug the coil, result in poor performance of the unit for refrigeration.

- Filter should be cleaned by using water or detergents depending on the degree of dirt, cleaning frequency according to the using environment, it is recommended a regular once a month.
- A comprehensive maintenance should be taken every two years. Chemical methods can be used to remove the scale in the coil, and water or detergent can be used to clean the dirt on the surface of the coil. Pay attention to check the water pipeline and wind duct for sealing and insulation in order to reduce energy loss.
- The most important thing is personal safety while doing maintenance.
- Insure that the insulation is enough between the maintenance engineer and machine.
- Maintenance engineers are forbidden entrance into the machine before the fan stop rotation.
- Insure that every electrical components is insulated from power before enter into machine.
- The instruction is used for the client to install, start up, operate and termly maintain , but not including long maintenance . The long maintenance of the unit should be done by the professional maintenance company.

Note

1: Straightness requirements and tension requirements should be satisfied at the same time after adjusting belt and pulleys.

2. When the service time has reached to 24 hours for the newly used belt, you must check belt tension and adjust it properly. Improper adjustment or no adjustment may result in belt lifespan reduction. Even more it will cause belt fracture.

3. Belt is consumable. It is normal when after 6-months usage, the belt is abraded and lose efficacy. You need to change a new belt at this time. If multi-belts rotate, you should change the group of belts simultaneously.

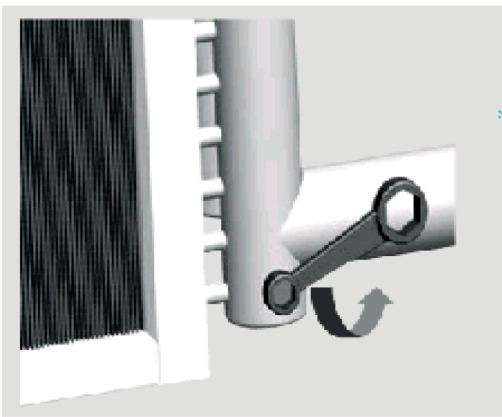

drained out the coil

Fig 4-1

5. COMMON FAULTS ANALYSIS, AND ELIMINATION

Table 5-1

Faults phenomenon	Possible Reasons	Resolving
Fan impeller vibration	Impeller off-centre, part breakdown Fan bearing support loose, bearing breakdown, oil starvation	Replace fan impeller Tightening bearing support, feed oil or replace
Fan high vibration	Fan fastening bolt is loose The pressure, air volume and system do not match	Check all the bolts and fasten Contact the technical supporter, re-match
Fan high noise	The pressure, air volume and system do not match, resulting in ultra-air volume	Contact the technical supporter, re-match
Unit water-drifted, water leakage	The pressure, air volume and system do not match, causing the heat exchanger face velocity being excessive, condensated water drifting to the lateral of the plate, the unit leaking Heat exchanger leak	Contact the technical supporter, re-match Fill the gaps or replace the heat exchanger
System small air volume	The fan is reversal, The pressure, air volume and system do not match, resulting in less air volume in the air outlet Filter, dirty coil block The air pipe system is short-circuit, air leakage The fan air inlet block, the length of the air outlet pipe is not enough or there is no straight pipe	Adjust the motor phase sequence Contact the technical supporter, re-match the pulley Clean the filter and coil Inspect the air pipe system and increase the length of straight pipe
Belt pulley, belt shake	The pulley connection is loose The motor pulley and fan pulley are not in the same plane	Tighten the pulley, adjust the two pulley for parallel Re-adjust fastening to protect both sides to coincide completely
Belt is easy to break	The belt is too tight or too loose The motor pulley and fan pulley are not in the same plane The pressure, air volume and system do not match, resulting in ultra-air volume, the belts being overload	Re-adjust belt tension to ensure a proper belt tension Re-adjust fastening to protect both sides to coincide completely Contact the technical supporter, and re-match
Belt pulley abnormal sound	Pulley is loose	Tighten the pulley
Motor vibration	The motor fastening bolts is loose The motor Bearing is oil starvation, damaged	Fix the motor fastening bolts Check the bearing, supply oil to it or the replace
Motor high current sound	The motor current is excessive, and lack of phase	Check the current and the phase sequence
Air pipe periodicity vibration	The system is instability Fan vibration transfer to the air pipe system	Adjust the system Add soft joint between the air vent and air pipe
Air pipe system whistling	The air pipe system is in the cracks, microporous result in high-speed air leakage	Inspect the system, add sealant in the cracks and micropore
Air pipe system squeak	Air pipe design is unreasonable, the air speed is too high Damping joint is too tight	Re-design the air pipe Adjust the damping Joint
Refrigerating capacity is less.	System air volume is not enough Pump head is not enough that causes the system water is small Selection of the unit is small	Analyze by the possibility of small amount of wind Increase the pump Re-select the new unit model

6. TYPICAL INSTALLATION DRAWING

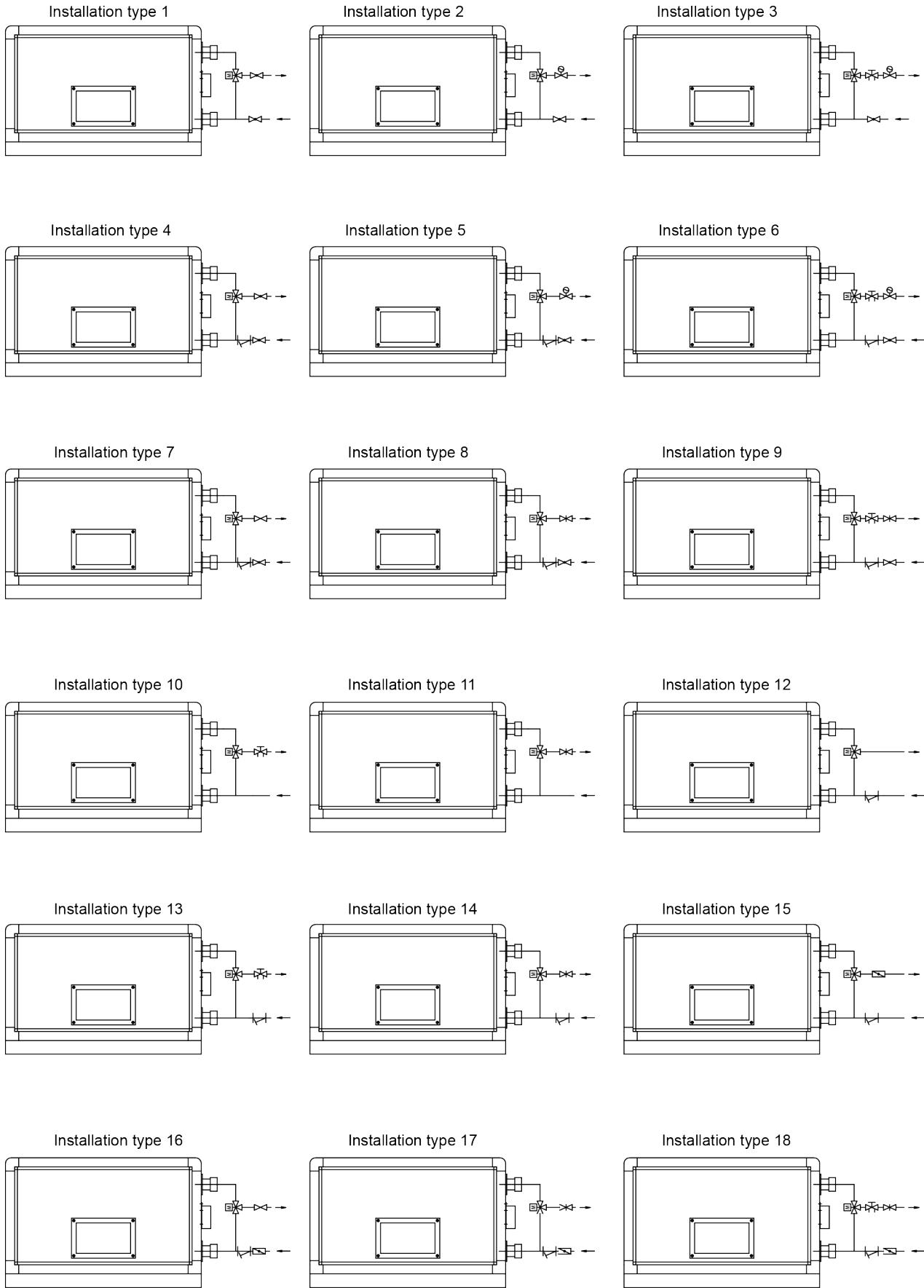

Typical examples of valve installation

No.	Valve arrange
1	Three way magnetic valve / ball valve
2	Three way magnetic valve / ball valve, motorised valve
3	Three way magnetic valve / balanced valve, motorised valve
4	Three way magnetic valve / ball valve, Y-shaped water filter
5	Three way magnetic valve / ball valve, Y-shaped water filter, motorised valve
6	Three way magnetic valve / ball valve, Y-shaped water filter, motorised valve, balanced valve
7	Three way magnetic valve / ball valve, shut-off valve, Y-shaped water filter, shut-off valve
8	Three way magnetic valve / ball valve, gate valve, Y-shaped water filter, shut-off valve
9	Three way magnetic valve / ball valve, Y-shaped water filter, gate valve, balanced valve
10	Three way magnetic valve / balanced valve
11	Three way magnetic valve / gate valve
12	Three way magnetic valve / Y-shaped water filter
13	Three way magnetic valve / Y-shaped water filter, balanced valve
14	Three way magnetic valve / Y-shaped water filter, gate valve
15	Three way magnetic valve / Y-shaped water filter, butterfly valve
16	Three way magnetic valve / Y-shaped water filter, butterfly valve, shut-off valve
17	Three way magnetic valve / Y-shaped water filter, butterfly valve, gate valve
18	Three way magnetic valve / Y-shaped water filter, butterfly valve, gate valve, balanced valve

Cutline:

Name	Legend
Gate valve	
Shut-off valve	
Ball valve	
Motorised valve	
Two-way magnetic valve	
Three-way magnetic valve	
Butterfly valve	
Balanced valve	
Y-shaped filter	



Importado por: **INTENSITY AIR, S. A. DE C. V.**

RFC: IAI-100609-SRA.

Río Amacuzac #1125, Col. Valle Ote., CP. 66269

San Pedro Garza García, Nuevo León, México

Note: Product specifications change from time to time as product improvements and developments are released and may vary from those in this document.